

SOT-23 Plastic-Encapsulate Transistors

TRANSISTOR (PNP)

FEATURES

- Driver Transistors
- AEC-Q101 qualified (Automotive grade with suffix " Q".)

MARKING:2H

MAXIMUM RATINGS ($T_a=25^{\circ}\text{C}$ unless otherwise noted)

Symbol	Parameter	Value	Unit
V_{CBO}	Collector-Base Voltage	-60	V
V_{CEO}	Collector-Emitter Voltage	-60	V
V_{EBO}	Emitter-Base Voltage	-4	V
I_{C}	Collector Current	-500	mA
P_{C}	Collector Power Dissipation	225	mW
$R_{\theta\text{JA}}$	Thermal Resistance From Junction To Ambient	556	$^{\circ}\text{C/W}$
$T_{\text{J}}, T_{\text{stg}}$	Operation Junction and Storage Temperature Range	-55~+150	$^{\circ}\text{C}$

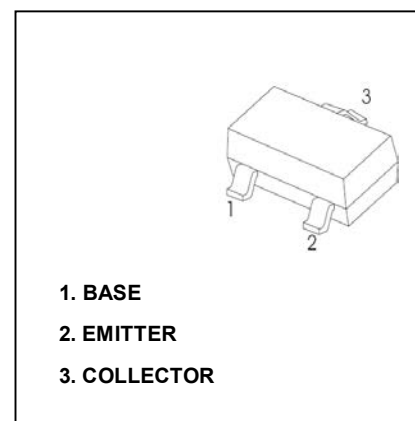

Equivalent Circuit

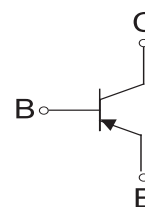
ELECTRICAL CHARACTERISTICS ($T_a=25^{\circ}\text{C}$ unless otherwise specified)

Parameter	Symbol	Test conditions	Min	Typ	Max	Unit
Collector-base breakdown voltage	$V_{(\text{BR})\text{CBO}}$	$I_{\text{C}}=-100\mu\text{A}, I_{\text{E}}=0$	-60			V
Collector-emitter breakdown voltage	$V_{(\text{BR})\text{CEO}}$	$I_{\text{C}}=-1\text{mA}, I_{\text{B}}=0$	-60			V
Emitter-base breakdown voltage	$V_{(\text{BR})\text{EBO}}$	$I_{\text{E}}=-100\mu\text{A}, I_{\text{C}}=0$	-4			V
Collector cut-off current	I_{CBO}	$V_{\text{CB}}=-60\text{V}, I_{\text{E}}=0$			-0.1	μA
Collector cut-off current	I_{CEO}	$V_{\text{CE}}=-60\text{V}, I_{\text{B}}=0$			-0.1	μA
DC current gain	$h_{\text{FE}(1)}$	$V_{\text{CE}}=-1\text{V}, I_{\text{C}}=-10\text{mA}$	100		400	
	$h_{\text{FE}(2)}$	$V_{\text{CE}}=-1\text{V}, I_{\text{C}}=-100\text{mA}$	100			
Collector-emitter saturation voltage	$V_{\text{CE}(\text{sat})}$	$I_{\text{C}}=-100\text{mA}, I_{\text{B}}=-10\text{mA}$			-0.25	V
Base-emitter voltage	V_{BE}	$V_{\text{CE}}=-1\text{V}, I_{\text{C}}=-100\text{mA}$			-1.2	V
Transition frequency	f_{T}	$V_{\text{CE}}=-1\text{V}, I_{\text{C}}=-100\text{mA}, f=100\text{MHz}$	50			MHz

SOT-23 Package Outline Dimensions

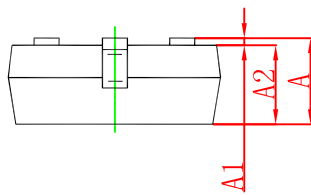
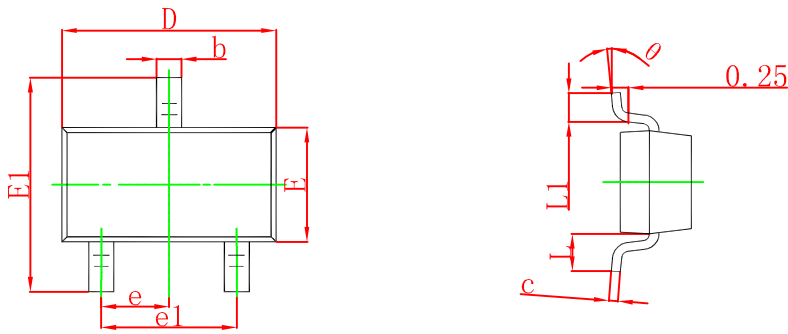

Symbol	Dimensions In Millimeters		Dimensions In Inches	
	Min	Max	Min	Max
A	0.900	1.150	0.035	0.045
A1	0.000	0.100	0.000	0.004
A2	0.900	1.050	0.035	0.041
b	0.300	0.500	0.012	0.020
c	0.080	0.150	0.003	0.006
D	2.800	3.000	0.110	0.118
E	1.200	1.400	0.047	0.055
E1	2.250	2.550	0.089	0.100
e	0.950 TYP		0.037 TYP	
e1	1.800	2.000	0.071	0.079
L	0.550 REF		0.022 REF	
L1	0.300	0.500	0.012	0.020
θ	0°	8°	0°	8°

SOT-23 Suggested Pad Layout

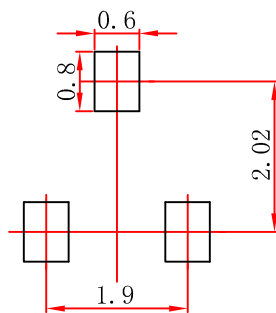

Note:

1. Controlling dimension: in millimeters.
2. General tolerance: ± 0.05 mm.
3. The pad layout is for reference purposes only.