

SOT-23 Plastic-Encapsulate Transistors

TRANSISTOR (NPN)

FEATURES

- High breakdown voltage
- Low collector-emitter saturation voltage
- AEC-Q101 qualified (Automotive grade with suffix " Q".)

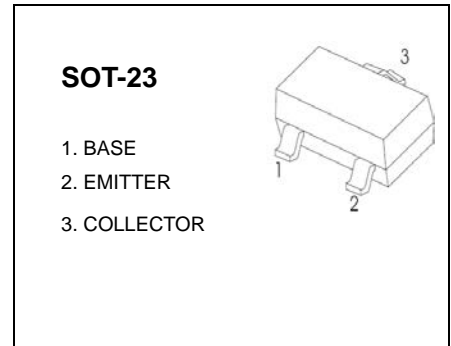

Marking: 1D

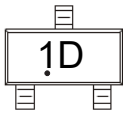

1D= Device code
Solid dot = Green molding compound device,
if none, the normal device.

MAXIMUM RATINGS (T_a=25°C unless otherwise noted)

Symbol	Parameter	Value	Unit
V _{CB0}	Collector-Base Voltage	300	V
V _{CEO}	Collector-Emitter Voltage	300	V
V _{EBO}	Emitter-Base Voltage	5	V
I _C	Collector Current -Continuous	0.3	A
I _{CM}	Collector Current-Peak	0.5	A
P _C	Collector Power dissipation	0.35	W
R _{θJA}	Thermal Resistance, junction to Ambient	357	°C/W
T _J , T _{stg}	Operation Junction and Storage Temperature Range	-55~+150	°C

Equivalent Circuit

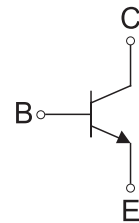

ELECTRICAL CHARACTERISTICS (T_a=25°C unless otherwise specified)

Parameter	Symbol	Test conditions	Min	Max	Unit
Collector-base breakdown voltage	V _{(BR)CBO}	I _C = 100μA, I _E =0	300		V
Collector-emitter breakdown voltage	V _{(BR)CEO}	I _C = 1mA, I _B =0	300		V
Emitter-base breakdown voltage	V _{(BR)EBO}	I _E = 100μA, I _C =0	5		V
Collector cut-off current	I _{CB0}	V _{CB} =200V, I _E =0		0.25	μA
Emitter cut-off current	I _{EBO}	V _{EB} = 5V, I _C =0		0.1	μA
DC current gain	h _{FE(1)}	V _{CE} = 10V, I _C = 1mA	60		
	h _{FE(2)}	V _{CE} = 10V, I _C =10mA	100	200	
	h _{FE(3)}	V _{CE} =10V, I _C =30mA	60		
Collector-emitter saturation voltage	V _{CE(sat)}	I _C =20mA, I _B = 2mA		0.2	V
Base-emitter saturation voltage	V _{BE(sat)}	I _C = 20mA, I _B =2mA		0.9	V
Transition frequency	f _T	V _{CE} = 20V, I _C = 10mA, f=30MHz	50		MHz

Typical Characteristics

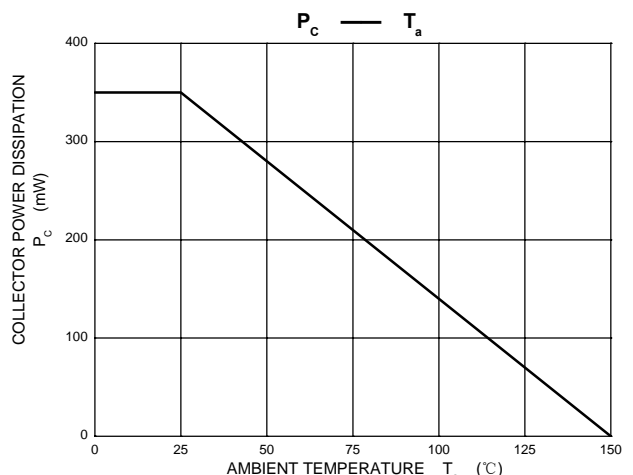
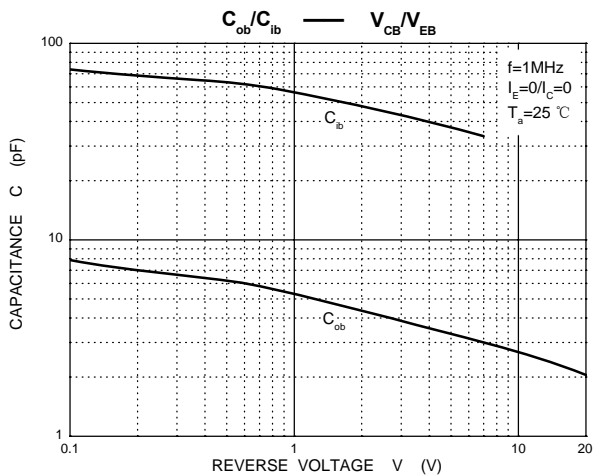
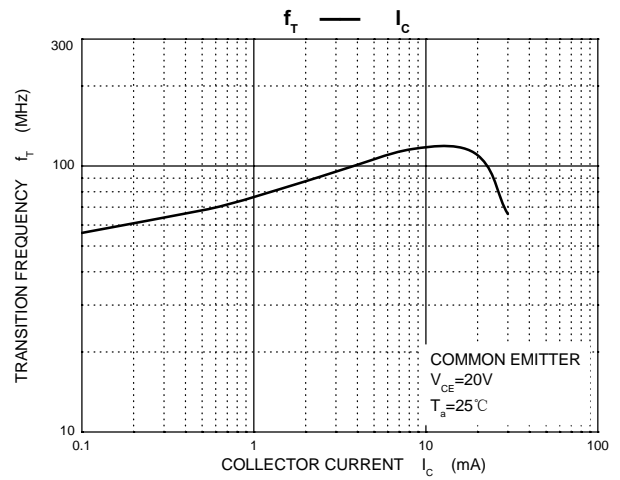
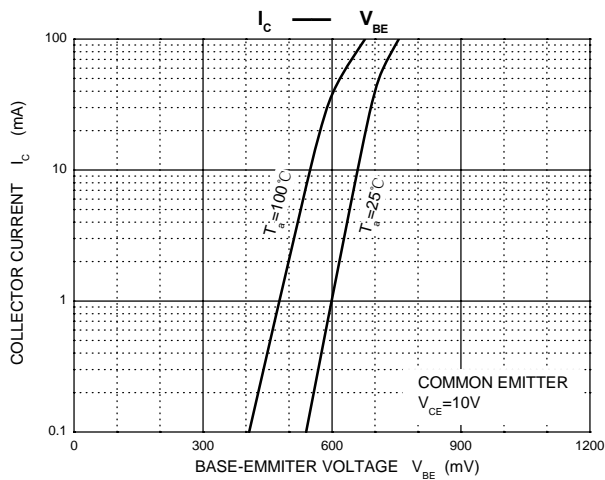
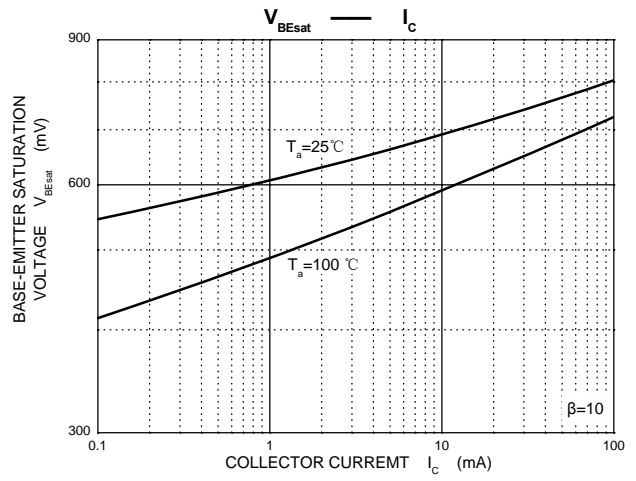
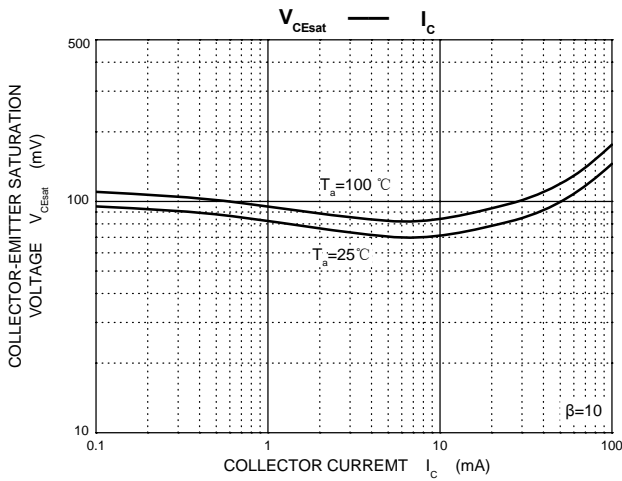
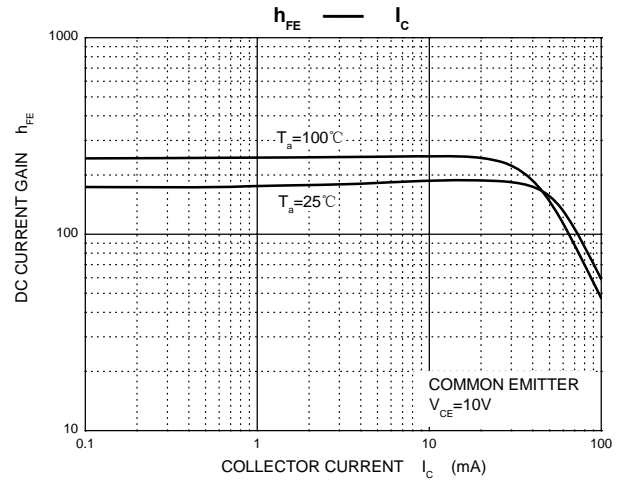
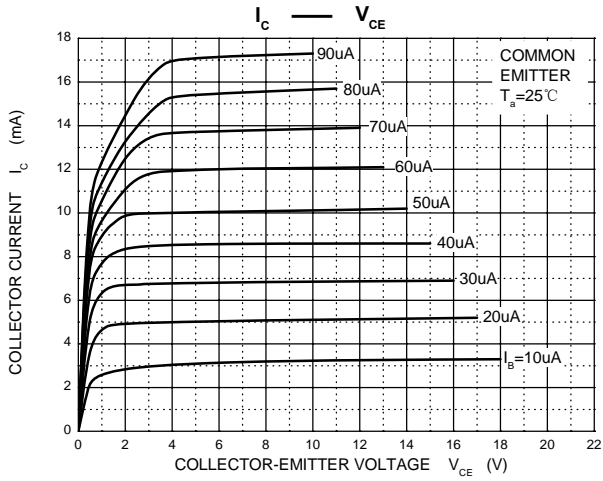

SOT-23 Package Outline Dimensions

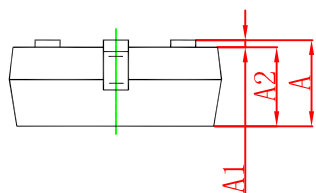
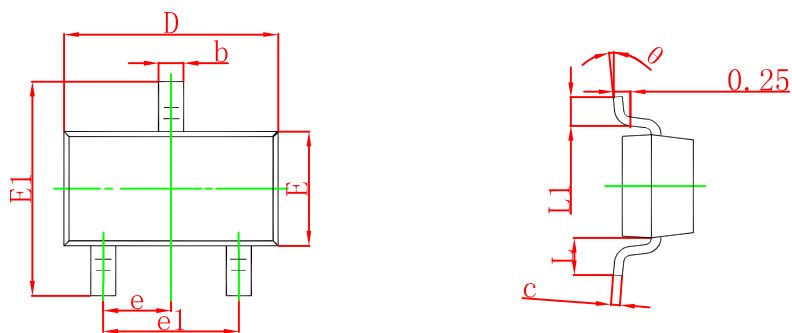

Symbol	Dimensions In Millimeters		Dimensions In Inches	
	Min	Max	Min	Max
A	0.900	1.150	0.035	0.045
A1	0.000	0.100	0.000	0.004
A2	0.900	1.050	0.035	0.041
b	0.300	0.500	0.012	0.020
c	0.080	0.150	0.003	0.006
D	2.800	3.000	0.110	0.118
E	1.200	1.400	0.047	0.055
E1	2.250	2.550	0.089	0.100
e	0.950 TYP		0.037 TYP	
e1	1.800	2.000	0.071	0.079
L	0.550 REF		0.022 REF	
L1	0.300	0.500	0.012	0.020
θ	0°	8°	0°	8°

SOT-23 Suggested Pad Layout

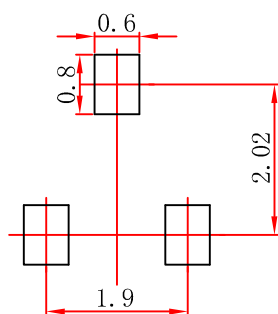

Note:

1. Controlling dimension: in millimeters.
2. General tolerance: ± 0.05 mm.
3. The pad layout is for reference purposes only.