

20V N-Channel MOSFET

Product Summary

$V_{(BR)DSS}$	$R_{DS(on)TYP}$	I_D
20V	10.4mΩ@10V	7A
	11.5mΩ@4.5V	
	12.0mΩ@3.8V	
	14.5mΩ@2.5V	

Feature

- Trench Technology Power MOSFET
- Low $R_{DS(ON)}$
- Low Gate Charge
- ESD Protected
- AEC-Q101 qualified (Automotive grade with suffix "Q".)

Application

- Load Switch
- DC/DC Converter

MARKING:

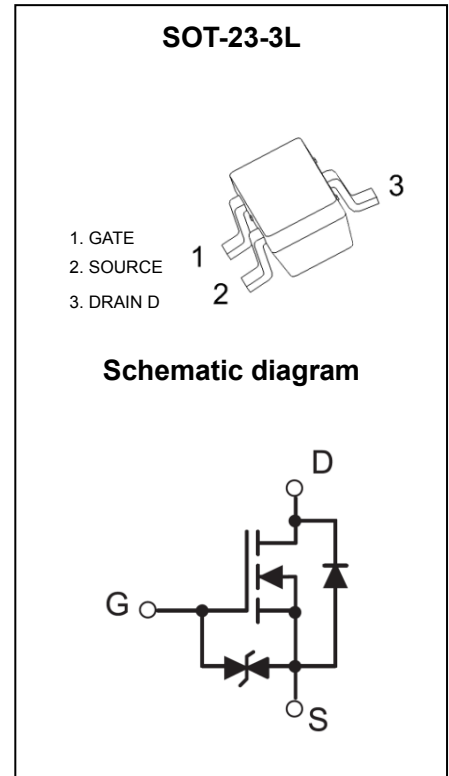
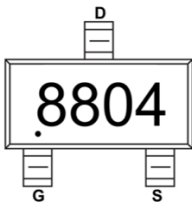
ABSOLUTE MAXIMUM RATINGS ($T_A = 25^\circ\text{C}$ unless otherwise noted)

Parameter	Symbol	Value	Unit
Drain - Source Voltage	V_{DS}	20	V
Gate - Source Voltage	V_{GS}	± 12	V
Continuous Drain Current ^{1,5}	I_D	7	A
Pulsed Drain Current ²	I_{DM}	28	A
Power Dissipation ^{4,5}	P_D	1.6	W
Thermal Resistance from Junction to Ambient ⁵	$R_{\theta JA}$	78	$^\circ\text{C}/\text{W}$
Junction Temperature	T_J	150	$^\circ\text{C}$
Storage Temperature	T_{STG}	-55~ +150	$^\circ\text{C}$

MOSFET ELECTRICAL CHARACTERISTICS ($T_J = 25^\circ\text{C}$ unless otherwise noted)

Parameter	Symbol	Test Condition	Min	Type	Max	Unit
Off Characteristics						
Drain - Source Breakdown Voltage	$V_{(BR)DSS}$	$V_{GS} = 0V, I_D = 250\mu A$	20			V
Zero Gate Voltage Drain Current	I_{DSS}	$V_{DS} = 16V, V_{GS} = 0V$			1	μA
Gate - Body Leakage Current	I_{GSS}	$V_{GS} = \pm 10V, V_{DS} = 0V$			± 5	μA
On Characteristics³						
Gate Threshold Voltage	$V_{GS(th)}$	$V_{DS} = V_{GS}, I_D = 250\mu A$	0.4	0.7	1	V
Drain-source On-resistance	$R_{DS(on)}$	$V_{GS} = 10V, I_D = 3A$		10.4	14	m Ω
		$V_{GS} = 4.5V, I_D = 3A$		11.5	15	
		$V_{GS} = 3.8V, I_D = 3A$		12.3	16	
		$V_{GS} = 2.5V, I_D = 3A$		14.5	19	
Dynamic Characteristics						
Input Capacitance	C_{iss}	$V_{DS} = 10V, V_{GS} = 0V, f = 1MHz$		681		pF
Output Capacitance	C_{oss}			159		
Reverse Transfer Capacitance	C_{rss}			5.18		
Switching Characteristics						
Total Gate Charge	Q_g	$V_{DD} = 10V, V_{GS} = 4.5V, I_D = 3A$		17.9		nC
Gate-source Charge	Q_{gs}			1.5		
Gate-drain Charge	Q_{gd}			4.7		
Turn-on Delay Time	$t_{d(on)}$	$V_{DS} = 10V, V_{GS} = 10V$ $RL = 1.2\Omega, R_{GEN} = 3\Omega$		2.5		ns
Turn-on Rise Time	t_r			7.2		
Turn-off Delay Time	$t_{d(off)}$			49		
Turn-off Fall Time	t_f			10.8		
Source - Drain Diode Characteristics						
Diode Forward Voltage ³	V_{SD}	$V_{GS} = 0V, I_S = 1A$			1	V

Notes :

- 1.The maximum current rating is limited by package.
- 2.Pulse Test : Pulse Width $\leq 10\mu s$, duty cycle $\leq 1\%$.
- 3.Pulse Test : Pulse Width $\leq 300\mu s$, duty cycle $\leq 2\%$.
- 4.The power dissipation P_D is limited by $T_{J(MAX)} = 150^\circ\text{C}$.
- 5.Device mounted on 1in^2 FR-4 board with 2oz. Copper, in a still air environment with $T_A = 25^\circ\text{C}$.

Typical Characteristics

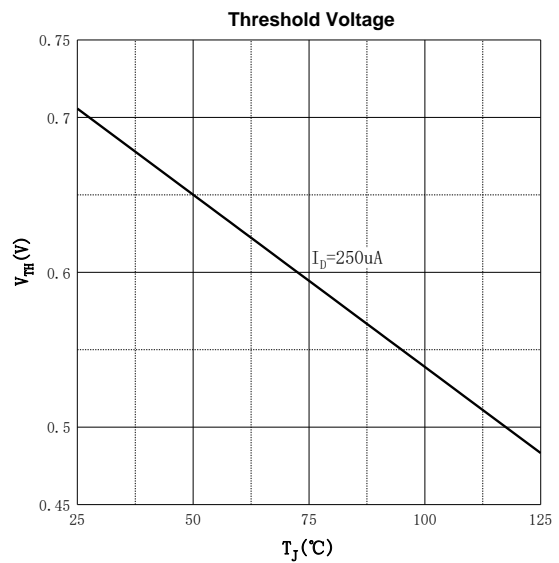
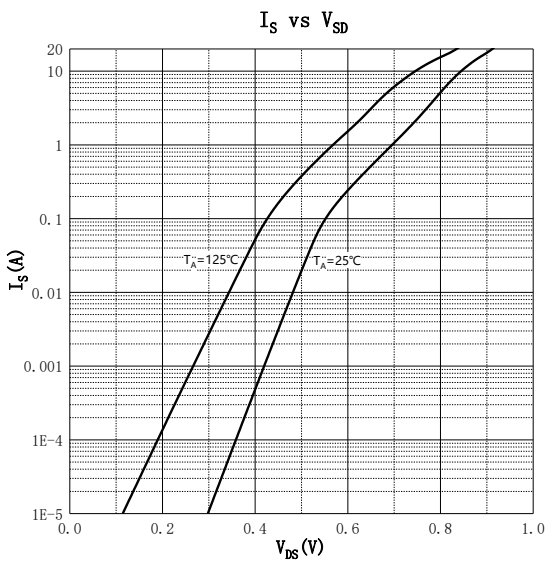
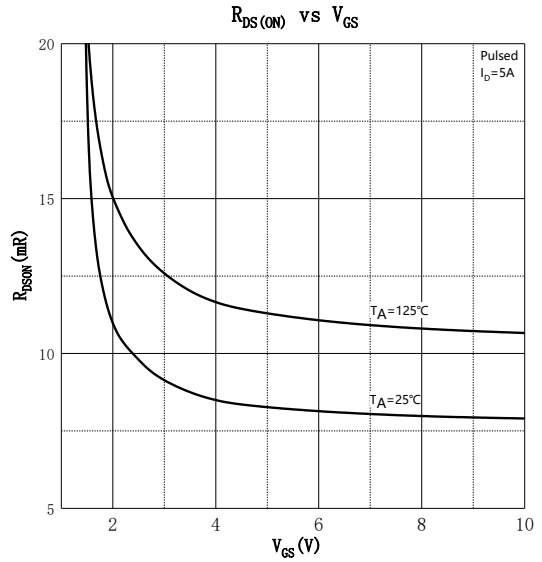
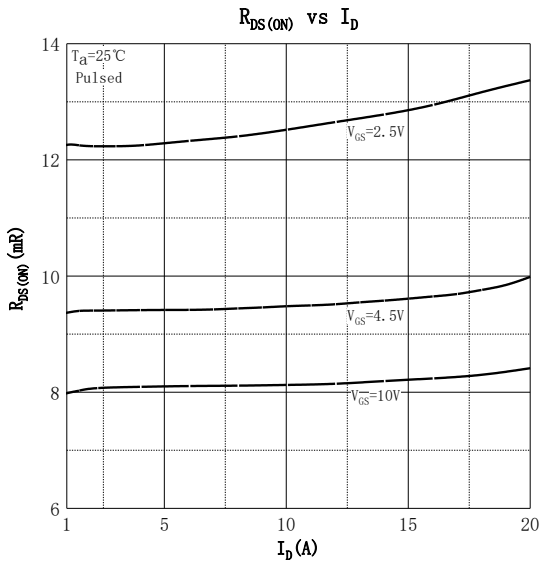
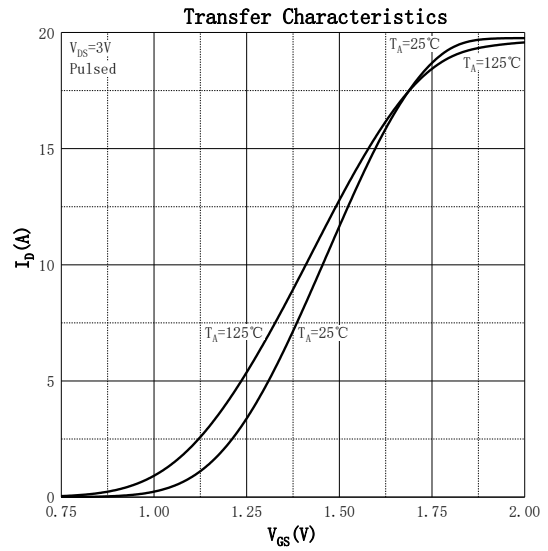
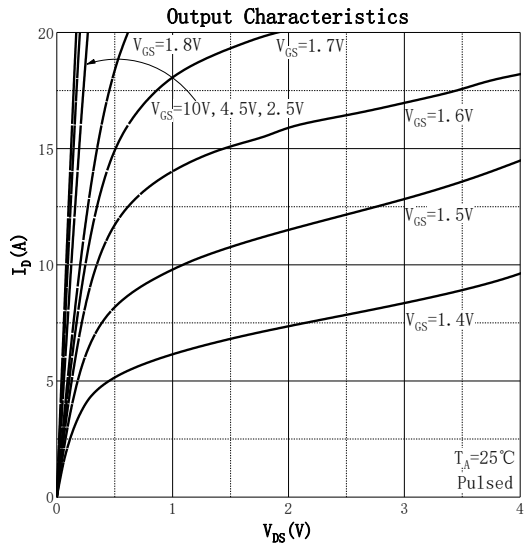

SOT-23-3L Package Information

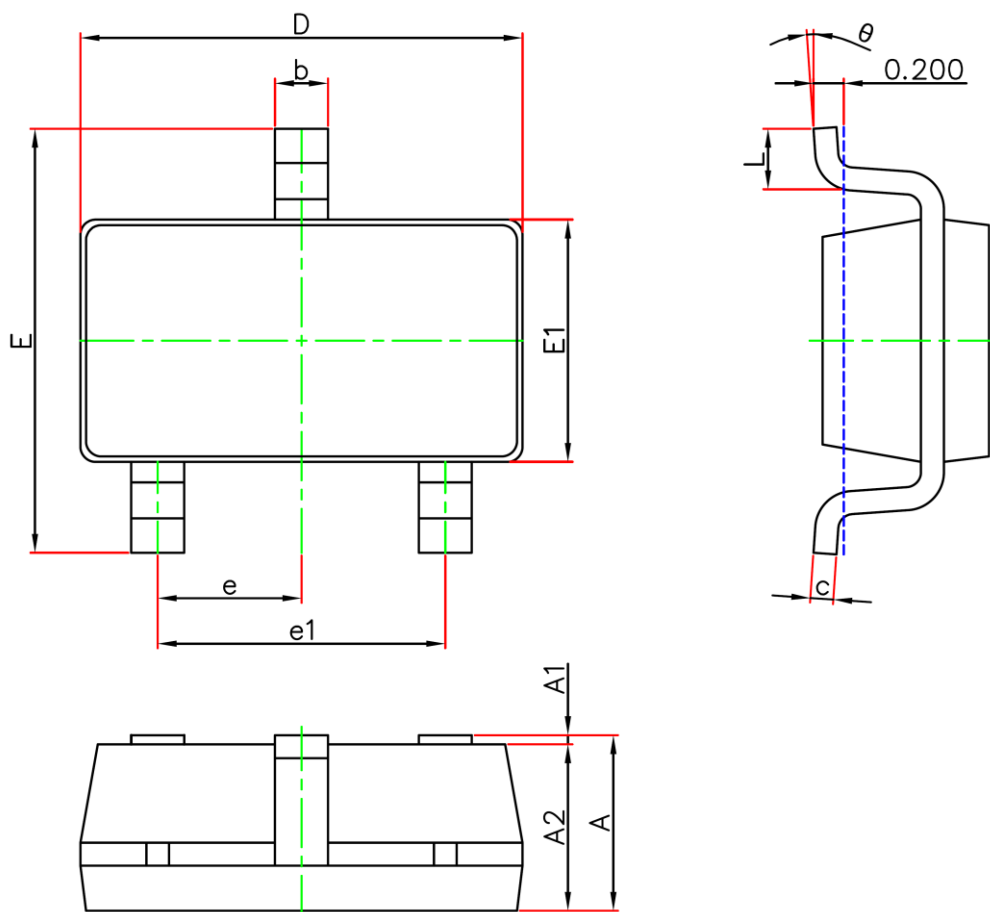

Symbol	Dimensions In Millimeters		Dimensions In Inches	
	Min.	Max.	Min.	Max.
A	1.050	1.250	0.041	0.049
A1	0	0.150	0.000	0.006
A2	1.050	1.250	0.041	0.049
b	0.300	0.500	0.012	0.020
c	0.100	0.200	0.004	0.008
D	2.820	3.020	0.111	0.119
E	2.650	2.950	0.104	0.116
E1	1.500	1.700	0.059	0.067
e	0.950TYP		0.037TYP	
e1	1.800	2.000	0.071	0.079
L	0.300	0.600	0.012	0.024
θ	0°	8°	0°	8°