

Transient Voltage Suppressors (TVS) Data Sheet

Features

- For surface mounted applications in order to optimize board space
- Low profile package
- Built-in strain relief
- Glass passivated junction
- Low inductance
- Excellent clamping capability
- 1500W peak pulse power capability at 10/1000 μ s waveform, repetition rate (duty cycle): 0.01%
- Fast response time
- Typical I_R less than 1 μ A above 10V
- High Temperature soldering: 260 $^{\circ}$ C/10 seconds at terminals
- Plastic package has underwriters laboratory flammability 94V-0
- Meets MSL level 1, per J-STD-020
- AEC-Q101 qualified (Automotive grade with suffix "Q".)
- Exsemi technology
- UL Certification:E492977
- Complies with following standards:
 - IEC 61000-4-2 (ESD) immunity test-- Air discharge: \pm 30kV
 - Contact discharge: \pm 30kV



Mechanical Data

- Case: JEDEC DO-214AB. Molded plastic over glass passivated junction
- Terminal: Solder plated, solderable per MIL-STD-750, Method 2026
- Polarity: Color band denotes cathode except bi-directional models

Applications

- AC/DC power supply
- I/O interface
- Low frequency signal transmission line

Maximum Ratings and Characteristics

Ratings at 25 $^{\circ}$ C ambient temperature unless otherwise specified.

| Rating | Symbol | Value | Units |
|---|-----------------|--------------|----------------|
| Peak pulse power dissipation at 10/1000 μ s waveform (Note1, Note2, Fig.1) | P_{PPM} | Minimum 1500 | Watts |
| Peak pulse current of at 10/1000 μ s waveform (Note 1, Fig.3) | I_{PPM} | See Table | Amps |
| Steady state power dissipation at $T_A=50^{\circ}$ C (Fig.5) | $P_{M(AV)}$ | 6.5 | Watts |
| Peak forward surge current, 8.3ms single half sine-wave superimposed on rated load, (JEDEC Method) (Note3, Fig.6) | I_{FSM} | 200 | Amps |
| Operating junction and Storage Temperature Range. | T_J, T_{STG} | -65 to +150 | $^{\circ}$ C |
| Typical thermal resistance junction to lead | $R_{\theta JL}$ | 15 | $^{\circ}$ C/W |
| Typical thermal resistance junction to ambient | $R_{\theta JA}$ | 75 | $^{\circ}$ C/W |

Notes: 1. Non-repetitive current pulse, per Fig.3 and derated above $T_A=25^{\circ}$ C per Fig.2.

2. Mounted on 8.0mm \times 8.0mm copper pads to each terminal.

3. 8.3ms single half sine-wave, or equivalent square wave, duty cycle=4 pulses per minutes maximum.

Electrical Characteristics ($T_A=25^{\circ}\text{C}$)

| Part Number | | Device Marking Code | | Reverse Stand-Off Voltage | Breakdown Voltage @ I_T | Test Current | Maximum Clamping Voltage @ I_{PP} | Peak Pulse Current | Reverse Leakage @ V_{RWM} |
|----------------|---------------|---------------------|-----|---------------------------|---------------------------|--------------|-------------------------------------|--------------------|-----------------------------|
| Unidirectional | Bidirectional | UNI | BI | $V_{RWM}(V)$ | $V_{BR}(V)$ | $I_T(mA)$ | $V_C(V)$ | $I_{PP}(A)$ | $I_R(\mu A)$ |
| SMCJ5.0A | SMCJ5.0CA | GDE | BDE | 5.0 | 6.40~7.00 | 10 | 9.2 | 163.0 | 800 |
| SMCJ6.0A | SMCJ6.0CA | GDG | BDG | 6.0 | 6.67~7.37 | 10 | 10.3 | 145.7 | 800 |
| SMCJ6.5A | SMCJ6.5CA | GDK | BDK | 6.5 | 7.22~7.98 | 10 | 11.2 | 134.0 | 500 |
| SMCJ7.0A | SMCJ7.0CA | GDM | BDM | 7.0 | 7.78~8.60 | 10 | 12.0 | 125.0 | 200 |
| SMCJ7.5A | SMCJ7.5CA | GDP | BDP | 7.5 | 8.33~9.21 | 1 | 12.9 | 116.3 | 100 |
| SMCJ8.0A | SMCJ8.0CA | GDR | BDR | 8.0 | 8.89~9.83 | 1 | 13.6 | 110.3 | 50 |
| SMCJ8.5A | SMCJ8.5CA | GDT | BDT | 8.5 | 9.44~10.40 | 1 | 14.4 | 104.2 | 20 |
| SMCJ9.0A | SMCJ9.0CA | GDV | BDV | 9.0 | 10.00~11.10 | 1 | 15.4 | 97.4 | 10 |
| SMCJ10A | SMCJ10CA | GDX | BDX | 10.0 | 11.10~12.30 | 1 | 17.0 | 88.3 | 5 |
| SMCJ11A | SMCJ11CA | GDZ | BDZ | 11.0 | 12.20~13.50 | 1 | 18.2 | 82.5 | 1 |
| SMCJ12A | SMCJ12CA | GEE | BEE | 12.0 | 13.30~14.70 | 1 | 19.9 | 75.4 | 1 |
| SMCJ13A | SMCJ13CA | GEG | BEG | 13.0 | 14.40~15.90 | 1 | 21.5 | 69.8 | 1 |
| SMCJ14A | SMCJ14CA | GEK | BEK | 14.0 | 15.60~17.20 | 1 | 23.2 | 64.7 | 1 |
| SMCJ15A | SMCJ15CA | GEM | BEM | 15.0 | 16.70~18.50 | 1 | 24.4 | 61.5 | 1 |
| SMCJ16A | SMCJ16CA | GEP | BEP | 16.0 | 17.80~19.70 | 1 | 26.0 | 57.7 | 1 |
| SMCJ17A | SMCJ17CA | GER | BER | 17.0 | 18.90~20.90 | 1 | 27.6 | 54.4 | 1 |
| SMCJ18A | SMCJ18CA | GET | BET | 18.0 | 20.00~22.10 | 1 | 29.2 | 51.4 | 1 |
| SMCJ20A | SMCJ20CA | GEV | BEV | 20.0 | 22.20~24.50 | 1 | 32.4 | 46.3 | 1 |
| SMCJ22A | SMCJ22CA | GEX | BEX | 22.0 | 24.40~26.90 | 1 | 35.5 | 42.3 | 1 |
| SMCJ24A | SMCJ24CA | GEZ | BEZ | 24.0 | 26.70~29.50 | 1 | 38.9 | 38.6 | 1 |
| SMCJ26A | SMCJ26CA | GFE | BFE | 26.0 | 28.90~31.90 | 1 | 42.1 | 35.7 | 1 |
| SMCJ28A | SMCJ28CA | GFG | BFG | 28.0 | 31.10~34.40 | 1 | 45.4 | 33.1 | 1 |
| SMCJ30A | SMCJ30CA | GFK | BFK | 30.0 | 33.30~36.80 | 1 | 48.4 | 31.0 | 1 |
| SMCJ33A | SMCJ33CA | GFM | BFM | 33.0 | 36.70~40.60 | 1 | 53.3 | 28.2 | 1 |
| SMCJ36A | SMCJ36CA | GFP | BFP | 36.0 | 40.00~44.20 | 1 | 58.1 | 25.9 | 1 |
| SMCJ40A | SMCJ40CA | GFR | BFR | 40.0 | 44.40~49.10 | 1 | 64.5 | 23.3 | 1 |
| SMCJ43A | SMCJ43CA | GFT | BFT | 43.0 | 47.80~52.80 | 1 | 69.4 | 21.7 | 1 |
| SMCJ45A | SMCJ45CA | GFV | BFV | 45.0 | 50.00~55.30 | 1 | 72.7 | 20.6 | 1 |
| SMCJ48A | SMCJ48CA | GFX | BFX | 48.0 | 53.30~58.90 | 1 | 77.4 | 19.4 | 1 |
| SMCJ51A | SMCJ51CA | GFZ | BFZ | 51.0 | 56.70~62.70 | 1 | 82.4 | 18.2 | 1 |

Electrical Characteristics ($T_A=25^{\circ}\text{C}$)

| Part Number | | Device Marking Code | | Reverse Stand-Off Voltage | Breakdown Voltage @ I_T | Test Current | Maximum Clamping Voltage @ I_{PP} | Peak Pulse Current | Reverse Leakage @ V_{RWM} |
|----------------|---------------|---------------------|-----|---------------------------|---------------------------|--------------|-------------------------------------|--------------------|-----------------------------|
| Unidirectional | Bidirectional | UNI | BI | $V_{RWM}(V)$ | $V_{BR}(V)$ | $I_T(mA)$ | $V_C(V)$ | $I_{PP}(A)$ | $I_R(\mu A)$ |
| SMCJ54A | SMCJ54CA | GGE | BGE | 54.0 | 60.00~66.30 | 1 | 87.1 | 17.3 | 1 |
| SMCJ58A | SMCJ58CA | GGG | BGG | 58.0 | 64.40~71.20 | 1 | 93.6 | 16.1 | 1 |
| SMCJ60A | SMCJ60CA | GGK | BGK | 60.0 | 66.70~73.70 | 1 | 96.8 | 15.5 | 1 |
| SMCJ64A | SMCJ64CA | GGM | BGM | 64.0 | 71.10~78.60 | 1 | 103.0 | 14.6 | 1 |
| SMCJ70A | SMCJ70CA | GGP | BGP | 70.0 | 77.80~86.00 | 1 | 113.0 | 13.3 | 1 |
| SMCJ75A | SMCJ75CA | GGR | BGR | 75.0 | 83.30~92.10 | 1 | 121.0 | 12.4 | 1 |
| SMCJ78A | SMCJ78CA | GGT | BGT | 78.0 | 86.70~95.80 | 1 | 126.0 | 11.9 | 1 |
| SMCJ85A | SMCJ85CA | GGV | BGV | 85.0 | 94.40~104.00 | 1 | 137.0 | 11.0 | 1 |
| SMCJ90A | SMCJ90CA | GGX | BGX | 90.0 | 100.00~111.00 | 1 | 146.0 | 10.3 | 1 |
| SMCJ100A | SMCJ100CA | GGZ | BGZ | 100.0 | 111.00~123.00 | 1 | 162.0 | 9.3 | 1 |
| SMCJ110A | SMCJ110CA | GHE | BHE | 110.0 | 122.00~135.00 | 1 | 177.0 | 8.5 | 1 |
| SMCJ120A | SMCJ120CA | GHG | BHG | 120.0 | 133.00~147.00 | 1 | 193.0 | 7.8 | 1 |
| SMCJ130A | SMCJ130CA | GHK | BHK | 130.0 | 144.00~159.00 | 1 | 209.0 | 7.2 | 1 |
| SMCJ150A | SMCJ150CA | GHM | BHM | 150.0 | 167.00~185.00 | 1 | 243.0 | 6.2 | 1 |
| SMCJ160A | SMCJ160CA | GHP | BHP | 160.0 | 178.00~197.00 | 1 | 259.0 | 5.8 | 1 |
| SMCJ170A | SMCJ170CA | GHR | BHR | 170.0 | 189.00~209.00 | 1 | 275.0 | 5.5 | 1 |
| SMCJ180A | SMCJ180CA | GHT | BHT | 180.0 | 201.00~222.00 | 1 | 292.0 | 5.1 | 1 |
| SMCJ190A | SMCJ190CA | GHU | BHU | 190.0 | 211.00~233.00 | 1 | 308.0 | 4.8 | 1 |
| SMCJ200A | SMCJ200CA | GHV | BHV | 200.0 | 224.00~247.00 | 1 | 324.0 | 4.6 | 1 |
| SMCJ210A | SMCJ210CA | GHW | BHW | 210.0 | 237.00~263.00 | 1 | 340.0 | 4.4 | 1 |
| SMCJ220A | SMCJ220CA | GHX | BHX | 220.0 | 246.00~272.00 | 1 | 356.0 | 4.2 | 1 |
| SMCJ250A | SMCJ250CA | GHZ | BHZ | 250.0 | 279.00~309.00 | 1 | 405.0 | 3.7 | 1 |
| SMCJ300A | SMCJ300CA | GJE | BJE | 300.0 | 335.00~371.00 | 1 | 486.0 | 3.1 | 1 |
| SMCJ350A | SMCJ350CA | GJG | BJG | 350.0 | 391.00~432.00 | 1 | 567.0 | 2.6 | 1 |
| SMCJ400A | SMCJ400CA | GJK | BJK | 400.0 | 447.00~494.00 | 1 | 648.0 | 2.3 | 1 |
| SMCJ440A | SMCJ440CA | GJM | BJM | 440.0 | 492.00~543.00 | 1 | 713.0 | 2.1 | 1 |

Notes: For bidirectional type having V_{RWM} of 10V and less, the I_R limit is double.

Ratings and Characteristic Curves ($T_A=25^{\circ}\text{C}$ unless otherwise noted)

Figure 1. Peak Pulse Power Rating Curve

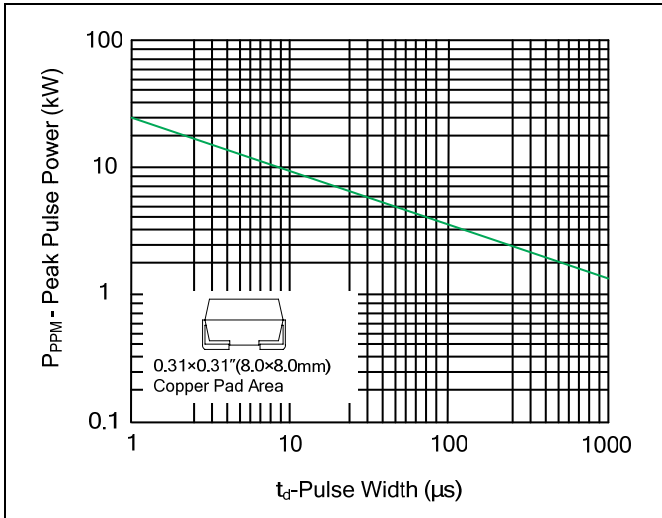

Figure 2. Pulse Derating Curve

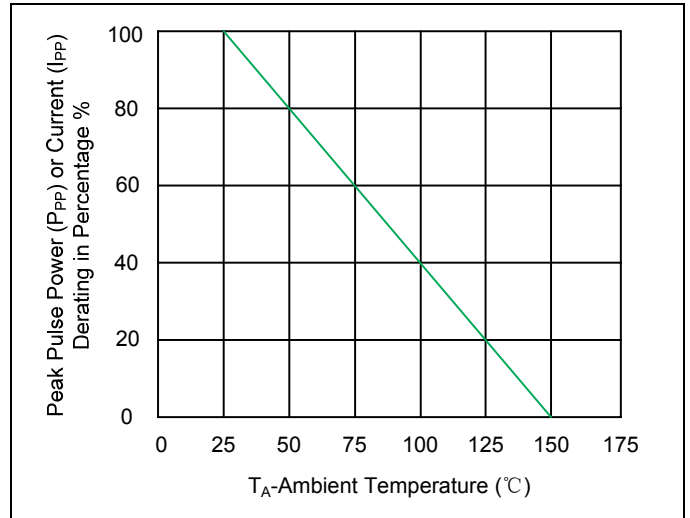

Figure 3. Pulse Waveform

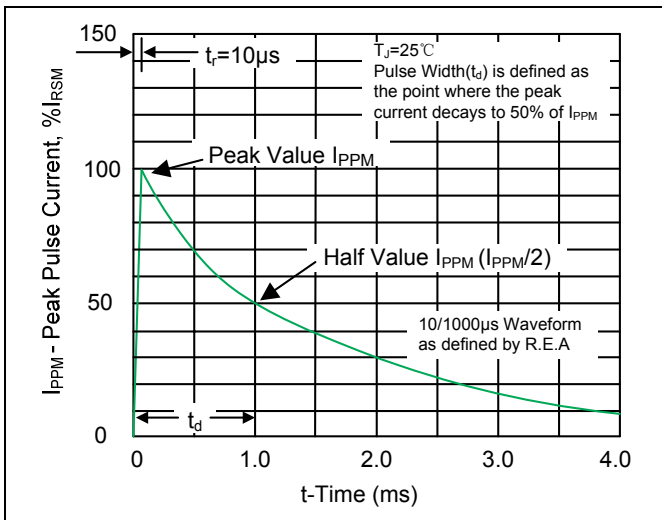

Figure 4. Typical Junction Capacitance

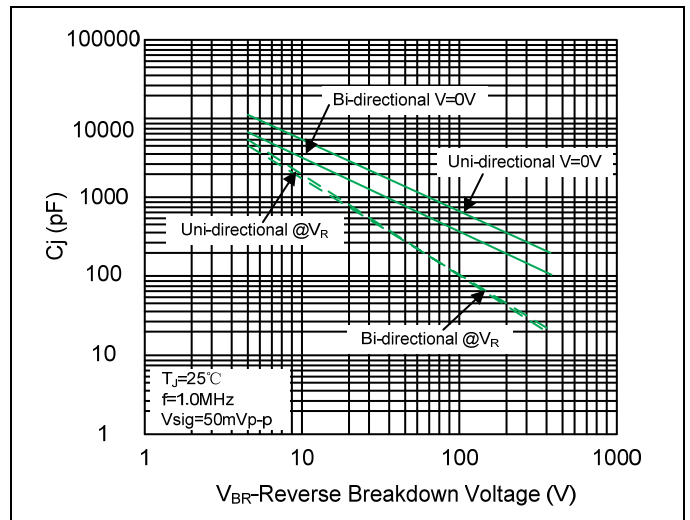

Figure 5. Steady State Power Dissipation Derating Curve

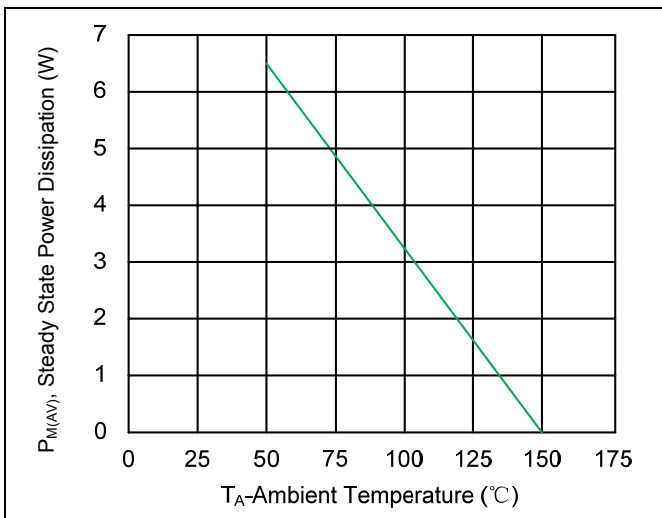
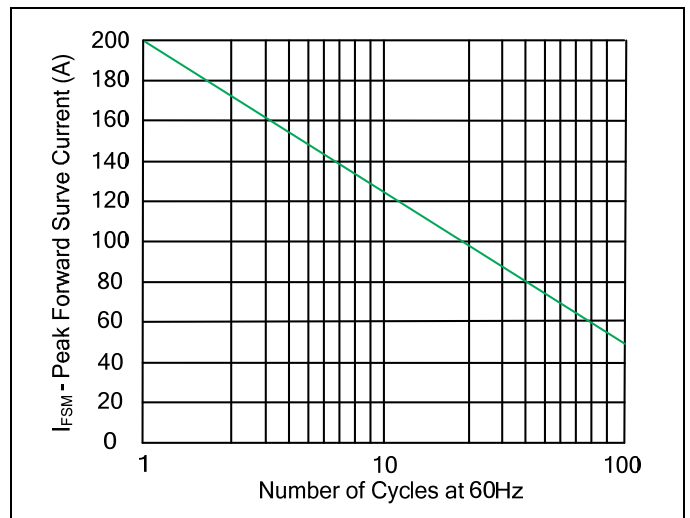

Figure 6. Maximum Non-Repetitive Forward Surge Current Uni-Directional Only



Recommended Soldering Conditions

Soldering Parameters

| | | |
|--|------------------------------------|------------------|
| Reflow Condition | Lead-free assembly | |
| Pre Heat | - Temperature Min ($T_{s(min)}$) | 150°C |
| | - Temperature Max ($T_{s(max)}$) | 200°C |
| | - Time (min to max) (t_s) | 60 – 180 secs |
| Average ramp up rate (Liquidus Temp (T_A) to peak) | 3°C/second max | |
| $T_{s(max)}$ to T_A - Ramp-up Rate | 3°C/second max | |
| Reflow | - Temperature (T_A) (Liquidus) | 217°C |
| | - Time (min to max) (t_s) | 60 – 150 seconds |
| Peak Temperature (T_p) | 260 ^{+0/-5} °C | |
| Time within 5°C of actual peak Temperature (t_p) | 20 – 40 seconds | |
| Ramp-down Rate | 6°C/second max | |
| Time 25°C to peak Temperature (T_p) | 8 minutes Max. | |
| Do not exceed | 260°C | |

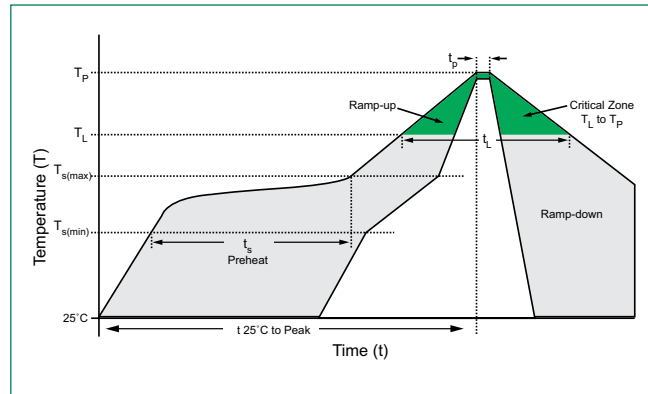

Physical Specifications

| | |
|----------|---|
| Case | JEDEC DO214AB. Molded plastic body over glass passivated junction |
| Polarity | Color band denotes positive end (cathode) except Bidirectional. |
| Terminal | Matte Tin-plated leads, Solderable per JESD22-B102 |

Environmental Specifications

| | |
|---------------------|--------------------------|
| High Temp. Storage | JESD22-A103 |
| HTRB | JESD22-A108 |
| Temperature Cycling | JESD22-A104 |
| MSL | JEDEC-J-STD-020, Level 1 |
| H3TRB | JESD22-A101 |
| RSH | JESD22-A111 |

Dimensions

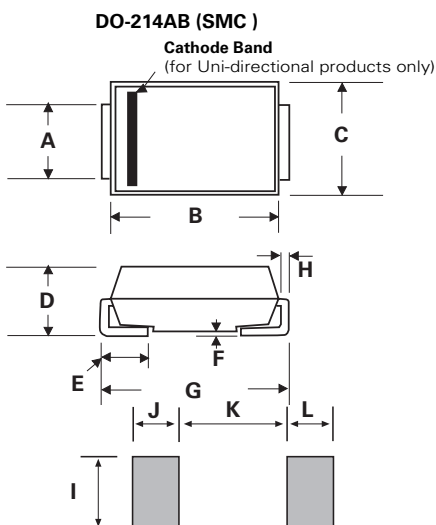

| Dimensions | Inches | | Millimeters | |
|------------|--------|-------|-------------|-------|
| | Min | Max | Min | Max |
| A | 0.108 | 0.128 | 2.750 | 3.250 |
| B | 0.260 | 0.291 | 6.600 | 7.400 |
| C | 0.220 | 0.246 | 5.590 | 6.250 |
| D | 0.078 | 0.108 | 1.980 | 2.750 |
| E | 0.030 | 0.060 | 0.760 | 1.520 |
| F | 0.002 | 0.008 | 0.051 | 0.203 |
| G | 0.303 | 0.323 | 7.700 | 8.200 |
| H | 0.006 | 0.012 | 0.152 | 0.305 |
| I | 0.129 | - | 3.300 | - |
| J | 0.094 | - | 2.400 | - |
| K | - | 0.165 | - | 4.200 |
| L | 0.094 | - | 2.400 | - |

Part Numbering System

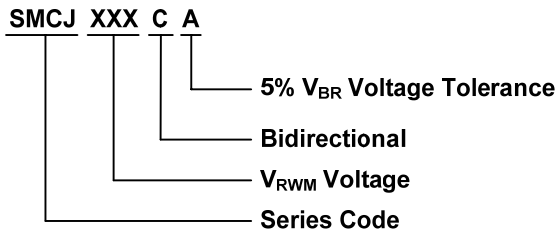

Part Marking System

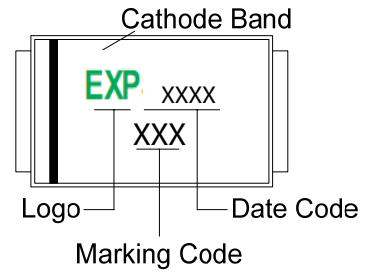

Packaging

| Part number | Component Package | Quantity | Packaging Option | Packaging Specification |
|-------------|-------------------|----------|----------------------------------|-------------------------|
| SMCJxxxXX | DO-214AB | 3000 | Tape & Reel - 16mm tape/13" reel | EIA STD RS-481 |

Tape and Reel Specification

