

Design for LED open circuit protection

The PL09BH series is a two terminal LED protector with low dropout voltage rated for max 2000mA bypass current. Low operation current at monitoring mode and high bypass current capability at triggered mode. Build-in reverse diode for bypass reversed supply voltage. The PL09BH series is designed for parallel connection with power LED. It bypasses LED driving current when LED at open circuit condition. It also bypasses LED driving current at reverse connected driving current to LED.

Features

- RoHS compliant
- Automatically reset after power cycle
- IEC-61000-4-2 ESD 30kv(Air),30kv(Contact)
- AEC-Q101 qualified (Automotive grade with suffix "Q".)
- Exsemi technology

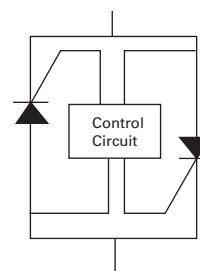

Main applications

- LED Lighting
- LED backlight for LCD TV/ Monitor
- High Power LED Protection

Electrical Characteristics (TA=25°C)

Part Number	V _{DRM} breakdown	I _{DRM}	V _{BO} breakdown	I _S	V _T	I _T	I _H	Critical rate of risedV/dt
	Min.	Max.	Max.	Max.	Max.	Max.	Min.	Max.
	V	μA	V	mA	V	A	mA	V
PL09BH	9	3	18	800	1.8	2	30	250V/μs

Electrical Parameters (TA=25°C)

Symbol	Parameter	Symbol	Parameter
V _{DRM}	Stand-off voltage, is measured at I _{DRM}	I _H	Holding current
I _{DRM}	Leakage current, is measured at V _{DRM}	I _T	ON-state current
V _{BR}	Breakover voltage, is measured at 100V/μs	V _T	On-state voltage
I _S	Breadover current		

Absolute Ratings (TA=25°C)

Symbol	Parameter	Value	Unit
Ts	Storage temperature range	-40 to +150	°C
Tj	Maximum junction temperature	150	°C
Ir	Minimum On-State Current, (TA = 25° C),	2000	mA

Ratings and Characteristic Curves (TA=25°C unless otherwise noted)

V-I Characteristics

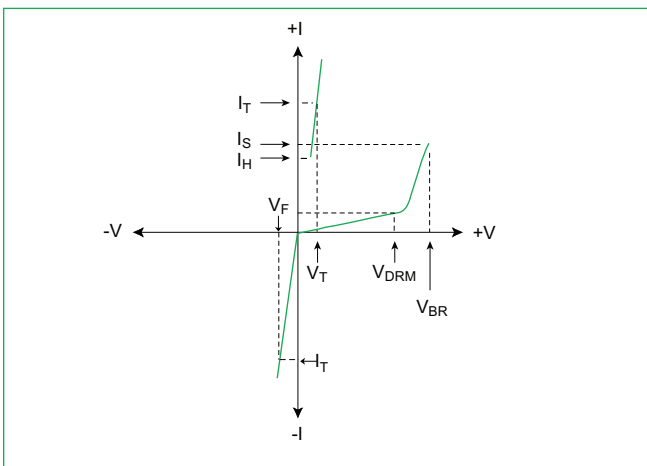

V_{BR} vs. Junction Temperature

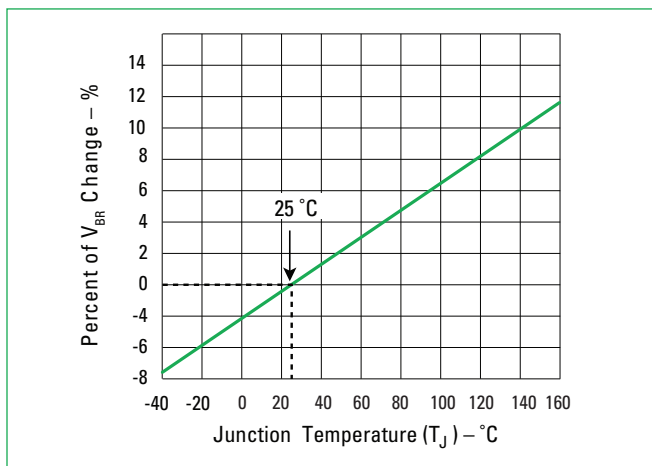

Normalized DC Holding Current vs. Case Temperature

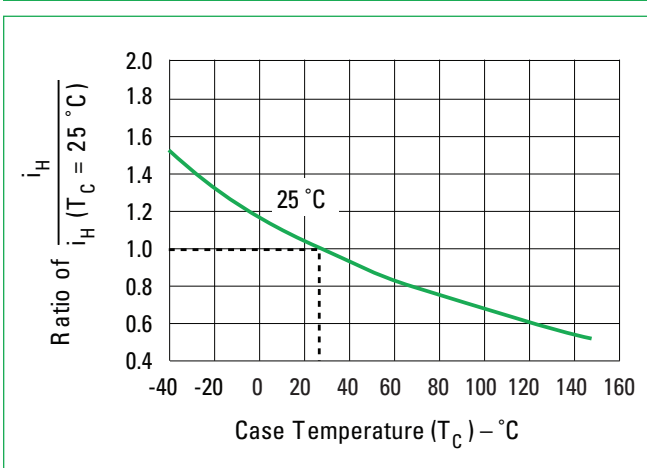

LED Interference Test Circuit

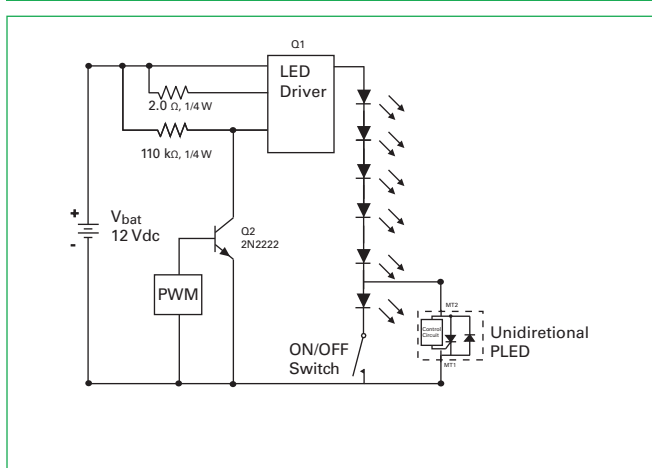

ORDERING INFORMATION

Device	Package	Shipping
PL09BH	SMB	3000 / Tape & Reel

PACKAGE DIMENSIONS

SMB DIMENSIONS

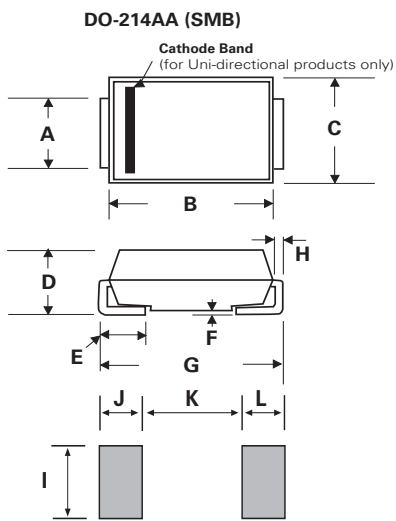

Dimensions	Inches		Millimeters	
	Min	Max	Min	Max
A	0.077	0.086	1.950	2.200
B	0.160	0.180	4.060	4.570
C	0.130	0.155	3.300	3.940
D	0.084	0.096	2.130	2.440
E	0.030	0.060	0.760	1.520
F	-	0.008	-	0.203
G	0.205	0.220	5.210	5.590
H	0.006	0.012	0.152	0.305
I	0.089	-	2.260	-
J	0.085	-	2.160	-
K	-	0.107	-	2.740
L	0.085	-	2.160	-