

Transient Voltage Suppressors (TVS) Data Sheet

Features

- Glass passivated junction
- Low zener impedance
- Excellent clamping capability
- 600W peak pulse power capability at 10/1000 μ s waveform, repetition rate (duty cycle): 0.01%
- Fast response time
- Typical I_R less than 1 μ A above 12V.
- High Temperature soldering guaranteed: 265 $^{\circ}$ C/10 seconds/.375", (9.5mm) lead length, 5lbs (2.3kg) tension
- Plastic package has underwriters laboratory flammability 94V-0
- Meets MSL level 1, per J-STD-020.
- AEC-Q101 qualified (Automotive grade with suffix "Q".)
- Exsemi technology
- UL Certification:E492977



Mechanical Data

- Case: JEDEC DO-15 Moulded plastic
- Terminal: Axial leads, solderable per MIL-STD-750, Method 2026
- Polarity: Color band denotes cathode except bi-directional models
- Mounting Position: Any

Applications

- AC/DC power supply
- I/O interface
- Low frequency signal transmission line

Maximum Ratings and Characteristics

Ratings at 25 $^{\circ}$ C ambient temperature unless otherwise specified.

Rating	Symbol	Value	Units
Peak pulse power dissipation at 10/1000 μ s waveform (Note1, Fig.1)	P_{PPM}	Minimum 600	Watts
Peak pulse current of at 10/1000 μ s waveform (Note 1, Fig.3)	I_{PPM}	See Table	Amps
Steady state power dissipation at $T_L=75^{\circ}$ C (Fig.5)	$P_{M(AV)}$	5.0	Watts
Peak forward surge current, 8.3ms single half sine-wave superimposed on rated load, (JEDEC Method) (Note2, Fig.6)	I_{FSM}	100	Amps
Operating junction and Storage Temperature Range.	T_J, T_{STG}	-55 to +175	$^{\circ}$ C
Typical thermal resistance junction to lead	$R_{\theta JL}$	20	$^{\circ}$ C/W
Typical thermal resistance junction to ambient	$R_{\theta JA}$	75	$^{\circ}$ C/W

Notes: 1. Non-repetitive current pulse, per Fig.3 and derated above $T_A=25^{\circ}$ C per Fig.2.

2. 8.3ms single half sine-wave, or equivalent square wave, duty cycle=4 pulses per minutes maximum.

Dimensions (DO-204AC/DO-15)

<p>The diagram shows a diode with a central body of length T and two leads of length L. The diameter of the body is d and the diameter of the lead is s. A cathode band is shown on the body. Dimensions are given in millimeters and inches.</p>	Symbol	Millimeters		Inches	
		Min.	Max.	Min.	Max.
	L	25.40	-	1.000	-
	T	5.80	7.60	0.230	0.300
	d	2.60	3.60	0.104	0.140
	s	0.71	0.86	0.028	0.034

Electrical Characteristics ($T_A=25^\circ\text{C}$)

Part Number		Reverse Stand-Off Voltage	Breakdown Voltage @ I_T	Test Current	Maximum Clamping Voltage @ I_{PP}	Peak Pulse Current	Reverse Leakage @ V_{RWM}
Unidirectional	Bidirectional	$V_{RWM}(V)$	$V_{BR}(V)$	$I_T(mA)$	$V_C(V)$	$I_{PP}(A)$	$I_R(\mu A)$
P6KE6.8A	P6KE6.8CA	5.80	6.45~7.14	10	10.5	58.1	1000
P6KE7.5A	P6KE7.5CA	6.40	7.13~7.88	10	11.3	54.0	500
P6KE8.2A	P6KE8.2CA	7.02	7.79~8.61	10	12.1	50.4	200
P6KE9.1A	P6KE9.1CA	7.78	8.65~9.55	1	13.4	45.5	50
P6KE10A	P6KE10CA	8.55	9.50~10.50	1	14.5	42.1	10
P6KE11A	P6KE11CA	9.40	10.50~11.60	1	15.6	39.1	5
P6KE12A	P6KE12CA	10.20	11.40~12.60	1	16.7	36.5	5
P6KE13A	P6KE13CA	11.10	12.40~13.70	1	18.2	33.5	1
P6KE15A	P6KE15CA	12.80	14.30~15.80	1	21.2	28.8	1
P6KE16A	P6KE16CA	13.60	15.20~16.80	1	22.5	27.1	1
P6KE18A	P6KE18CA	15.30	17.10~18.90	1	25.2	24.2	1
P6KE20A	P6KE20CA	17.10	19.00~21.00	1	27.7	22.0	1
P6KE22A	P6KE22CA	18.80	20.90~23.10	1	30.6	19.9	1
P6KE24A	P6KE24CA	20.50	22.80~25.20	1	33.2	18.4	1
P6KE27A	P6KE27CA	23.10	25.70~28.40	1	37.5	16.3	1
P6KE30A	P6KE30CA	25.60	28.50~31.50	1	41.4	14.7	1
P6KE33A	P6KE33CA	28.20	31.40~34.70	1	45.7	13.3	1
P6KE36A	P6KE36CA	30.80	34.20~37.80	1	49.9	12.2	1
P6KE39A	P6KE39CA	33.30	37.10~41.00	1	53.9	11.3	1
P6KE43A	P6KE43CA	36.80	40.90~45.20	1	59.3	10.3	1

Electrical Characteristics ($T_A=25^{\circ}\text{C}$)

Part Number		Reverse Stand-Off Voltage	Breakdown Voltage @ I_T	Test Current	Maximum Clamping Voltage @ I_{PP}	Peak Pulse Current	Reverse Leakage @ V_{RWM}
Unidirectional	Bidirectional	$V_{RWM}(V)$	$V_{BR}(V)$	$I_T(mA)$	$V_C(V)$	$I_{PP}(A)$	$I_R(\mu A)$
P6KE47A	P6KE47CA	40.20	44.70~49.40	1	64.8	9.4	1
P6KE51A	P6KE51CA	43.60	48.50~53.60	1	70.1	8.7	1
P6KE56A	P6KE56CA	47.80	53.20~58.80	1	77.0	7.9	1
P6KE62A	P6KE62CA	53.00	58.90~65.10	1	85.0	7.2	1
P6KE68A	P6KE68CA	58.10	64.60~71.40	1	92.0	6.6	1
P6KE75A	P6KE75CA	64.10	71.30~78.80	1	103.0	5.9	1
P6KE82A	P6KE82CA	70.10	77.90~86.10	1	113.0	5.4	1
P6KE91A	P6KE91CA	77.80	86.50~95.50	1	125.0	4.9	1
P6KE100A	P6KE100CA	85.50	95.00~105.00	1	137.0	4.5	1
P6KE110A	P6KE110CA	94.00	105.00~116.00	1	152.0	4.0	1
P6KE120A	P6KE120CA	102.00	114.00~126.00	1	165.0	3.7	1
P6KE130A	P6KE130CA	111.00	124.00~137.00	1	179.0	3.4	1
P6KE150A	P6KE150CA	128.00	143.00~158.00	1	207.0	2.9	1
P6KE160A	P6KE160CA	136.00	152.00~168.00	1	219.0	2.8	1
P6KE170A	P6KE170CA	145.00	162.00~179.00	1	234.0	2.6	1
P6KE180A	P6KE180CA	154.00	171.00~189.00	1	246.0	2.5	1
P6KE200A	P6KE200CA	171.00	190.00~210.00	1	274.0	2.2	1
P6KE220A	P6KE220CA	185.00	209.00~231.00	1	328.0	1.9	1
P6KE250A	P6KE250CA	214.00	237.00~263.00	1	344.0	1.8	1
P6KE300A	P6KE300CA	256.00	285.00~315.00	1	414.0	1.5	1
P6KE350A	P6KE350CA	300.00	332.00~368.00	1	482.0	1.3	1
P6KE400A	P6KE400CA	342.00	380.00~420.00	1	548.0	1.1	1
P6KE440A	P6KE440CA	376.00	418.00~462.00	1	602.0	1.04	1
P6KE480A	P6KE480CA	408.00	456.00~504.00	1	658.0	0.9	1
P6KE510A	P6KE510CA	434.00	485.00~535.00	1	698.0	0.9	1
P6KE530A	P6KE530CA	450.00	503.50~556.50	1	725.0	0.8	1
P6KE540A	P6KE540CA	459.00	513.00~567.00	1	740.0	0.8	1
P6KE550A	P6KE550CA	467.00	522.50~577.50	1	760.0	0.8	1
P6KE600A	P6KE600CA	512.00	570.00~630.00	1	828.0	0.75	1

Notes: For bidirectional type having V_{RWM} of 10V and less, the I_R limit is double.

Ratings and Characteristic Curves ($T_A=25^{\circ}\text{C}$ unless otherwise noted)

Figure 1. Peak Pulse Power Rating Curve

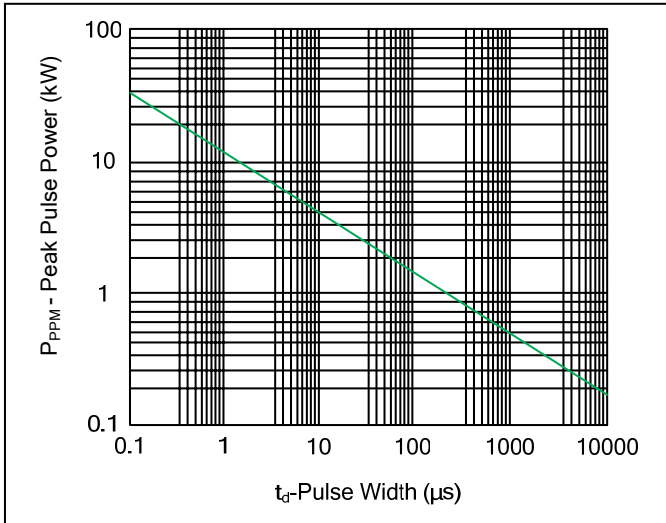

Figure 2. Pulse Derating Curve

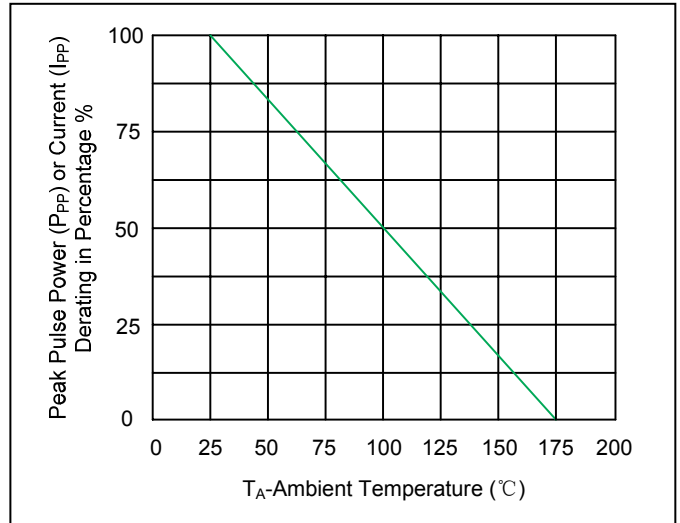

Figure 3. Pulse Waveform

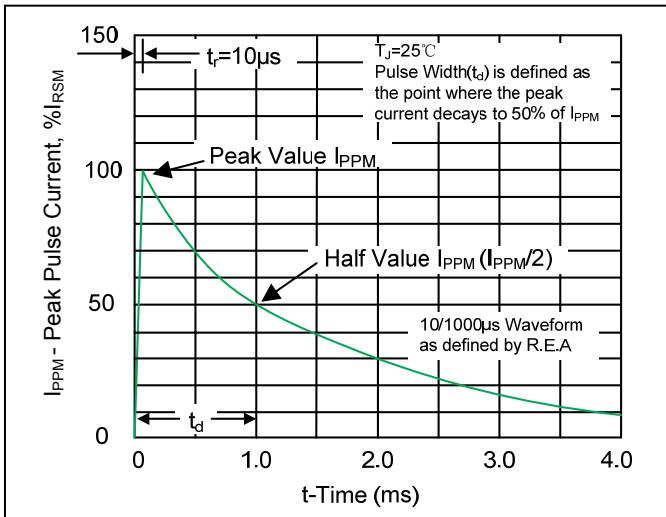

Figure 4. Typical Junction Capacitance

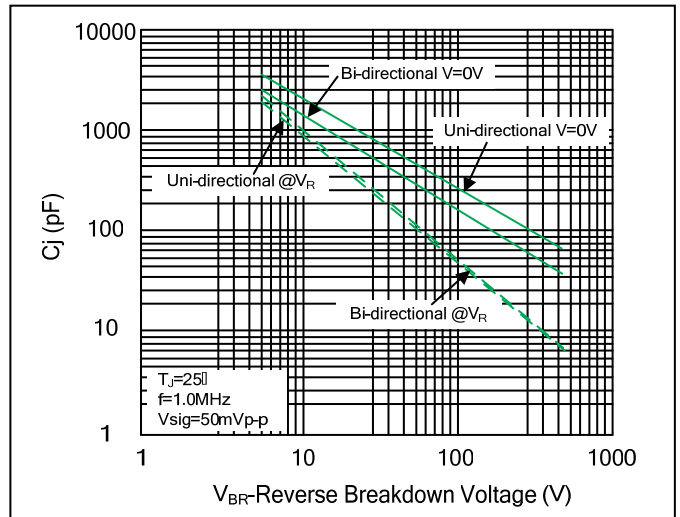

Figure 5. Steady State Power Dissipation Derating Curve

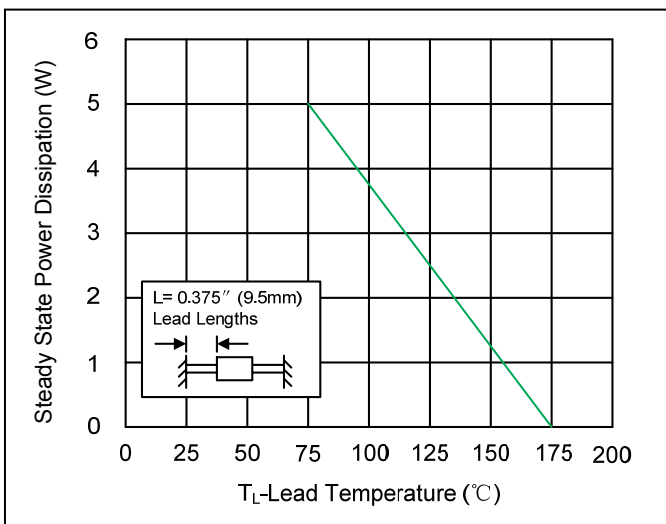
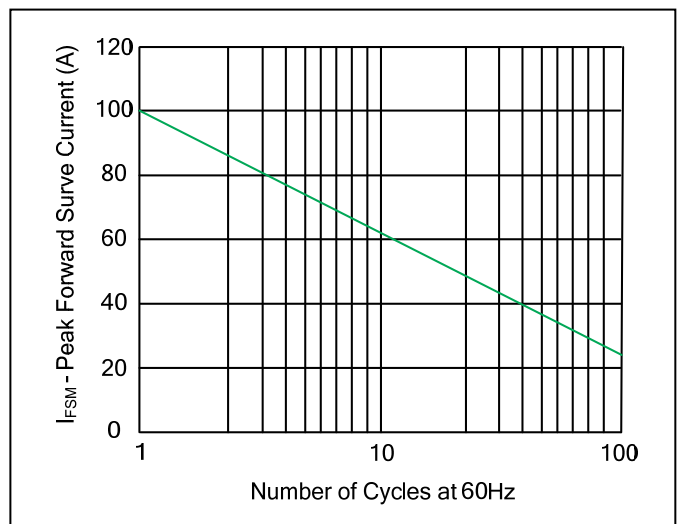

Figure 6. Maximum Non-Repetitive Forward Surge Current Uni-Directional Only



Recommended Soldering Conditions

Soldering Parameters

Reflow Condition		Lead-free assembly
Pre Heat	- Temperature Min ($T_{s(min)}$)	150°C
	- Temperature Max ($T_{s(max)}$)	200°C
	- Time (min to max) (t_s)	60 – 180 secs
Average ramp up rate (Liquidus Temp (T_A) to peak)		3°C/second max
$T_{s(max)}$ to T_A - Ramp-up Rate		3°C/second max
Reflow	- Temperature (T_A) (Liquidus)	217°C
	- Time (min to max) (t_s)	60 – 150 seconds
Peak Temperature (T_p)		260 ^{+0/-5} °C
Time within 5°C of actual peak Temperature (t_p)		20 – 40 seconds
Ramp-down Rate		6°C/second max
Time 25°C to peak Temperature (T_p)		8 minutes Max.
Do not exceed		260°C

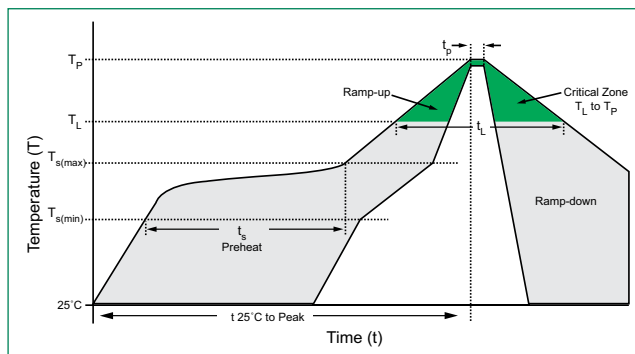

Flow/Wave Soldering (Solder Dipping)

Peak Temperature :	265°C
Dipping Time :	10 seconds
Soldering :	1 time

Physical Specifications

Weight	0.015oz., 0.4g
Case	JEDEC DO-204AC (DO-15) molded plastic body over passivated junction.
Polarity	Color band denotes the cathode except Bipolar.
Terminal	Matte Tin axial leads, solderable per JESD22-B102.

Environmental Specifications

High Temp. Storage	JESD22-A103
HTRB	JESD22-A108
Temperature Cycling	JESD22-A104
H3TRB	JESD22-A101
RSH	JESD22-B106

Dimensions

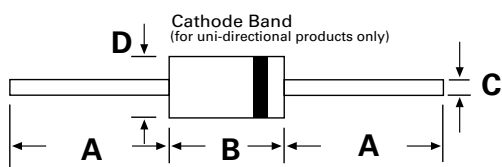

DO-204AC (DO-15)

Dimensions	Inches		Millimeters	
	Min	Max	Min	Max
A	1.000	-	25.40	-
B	0.230	0.300	5.80	7.60
C	0.028	0.034	0.71	0.86
D	0.104	0.140	2.60	3.60

Part Numbering System

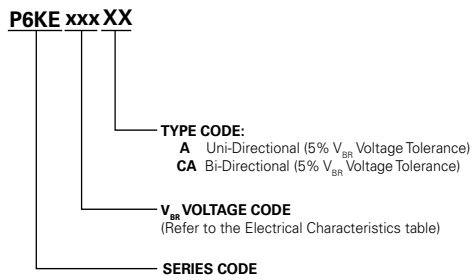

Part Marking System

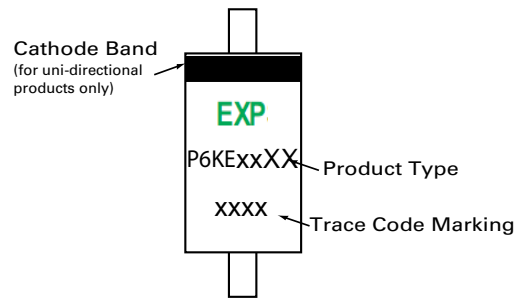

Packaging

Part Number	Component Package	Quantity	Packaging Option	Packaging Specification
P6KExxxXX	DO-204AC	2000	Tape & Reel	EIA STD RS-296

Tape and Reel Specification

Tape	Symbol	Dimension (mm)
	A	5.0±0.5
	B	53.0±1.0
	Z	1.2Max.
	T	6.0±0.4
	E	0.8Max.
	L1-L2	1.0Max.
	C	