

## ESD Protection Diode

### Features

- \* Ultra small package: 1.0x0.6x0.5mm
- \* Ultra low capacitance: 0.3pF typical
- \* Ultra low leakage: nA level
- \* Low operating voltage: 5V
- \* Low clamping voltage
- \* 2-pin leadless package
- \* Complies with following standards:
  - IEC 61000 4 2 (ESD) immunity test
    - Air discharge:  $\pm 20\text{kV}$
    - Contact discharge:  $\pm 15\text{kV}$
  - IEC61000-4-5 (Lightning) 4A (8/20 $\mu\text{s}$ )
- \* RoHS Compliant
- \* Lead Finish: NiPdAu
- \* AEC-Q101 qualified (Automotive grade with suffix "Q!")

### Applications

- \* Smart phones
- \* Display Ports
- \* MDDI Ports
- \* USB Ports
- \* Digital Video Interface (DVI)
- \* PCI Express and Serial SATA Ports

### Circuit Diagram

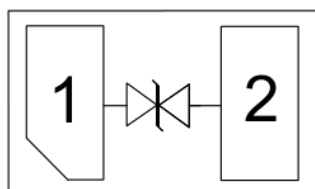

### Marking Diagram



**Transparent top view**

5F:Device Marking Code

### Ordering Information

Part Number	Packaging	Reel Size
EPDFN20515	10000/Tape & Reel	7 inch

### Absolute Maximum Ratings ( $T_A=25^{\circ}\text{C}$ unless otherwise specified)

Parameter	Symbol	Value	Unit
Peak Pulse Power (8/20 $\mu\text{s}$ )	Ppk	80	W
Peak Pulse Current (8/20 $\mu\text{s}$ )	IPP	4	A
ESD per IEC 61000-4-2 (Air)	VESD	$\pm 20$	kV
ESD per IEC 61000-4-2 (Contact)		$\pm 15$	
Operating Temperature Range	TJ	-55 to +125	$^{\circ}\text{C}$
Storage Temperature Range	Tstg	-55 to +150	$^{\circ}\text{C}$

### Electrical Characteristics ( $T_A=25^{\circ}\text{C}$ unless otherwise specified)

Parameter	Symbol	Test Condition	Min	Typ	Max	Unit
Reverse Working Voltage	$V_{RWM}$				5.0	V
Breakdown Voltage	$V_{BR}$	$I_T = 1\text{mA}$	6.0	7.5	8.5	V
Reverse Leakage Current	$I_R$	$V_{RWM} = 5.0\text{V}$			0.5	$\mu\text{A}$
Clamping Voltage	$V_C$	$I_{PP} = 1\text{A}$ (8 x 20 $\mu\text{s}$ pulse)			12	V
Clamping Voltage	$V_C$	$I_{PP} = 4\text{A}$ (8 x 20 $\mu\text{s}$ pulse)		19	22	V
Junction Capacitance	$C_J$	$V_R = 0\text{V}$ , $f = 1\text{MHz}$		0.3	0.45	pF

### Portion Electronics Parameter

Symbol	Parameter
$I_T$	Test Current
$I_{PP}$	Maximum Reverse Peak Pulse Current
$V_C$	Clamping Voltage @ $I_C$

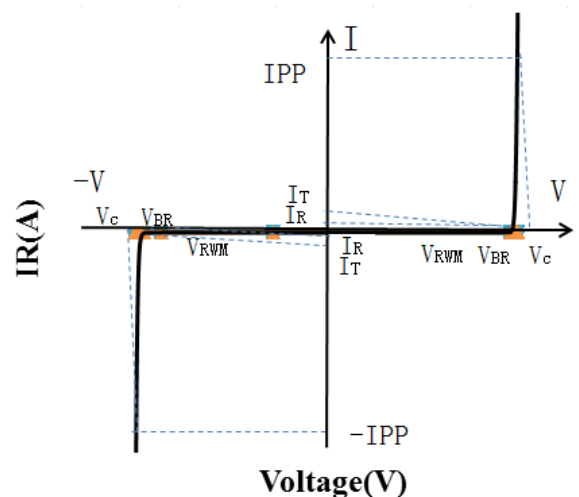

Typical Performance Characteristics ( $T_A=25^{\circ}\text{C}$  unless otherwise Specified)

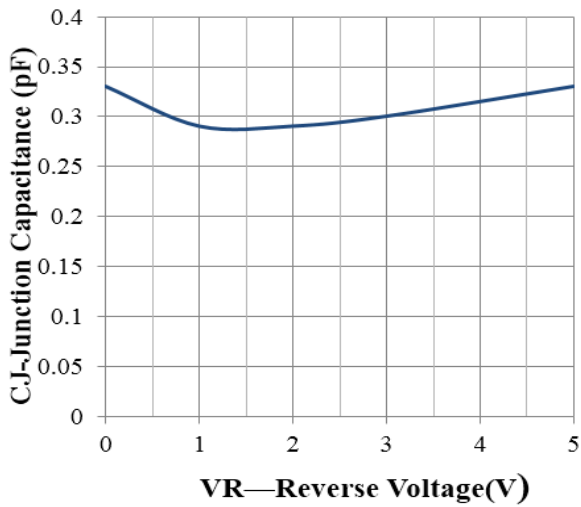

Junction Capacitance vs. Reverse Voltage

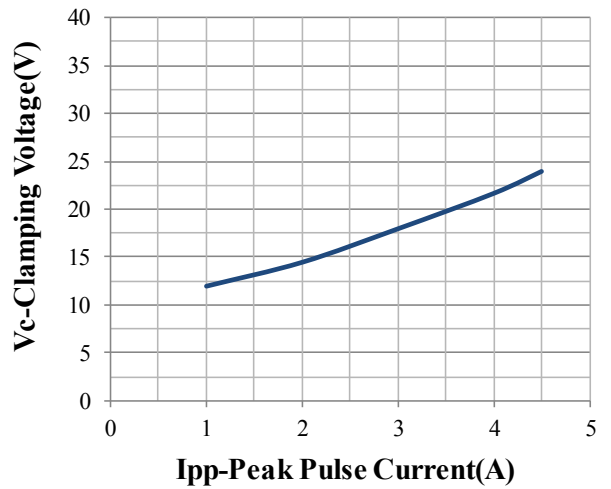

Clamping Voltage vs. Peak Pulse Current

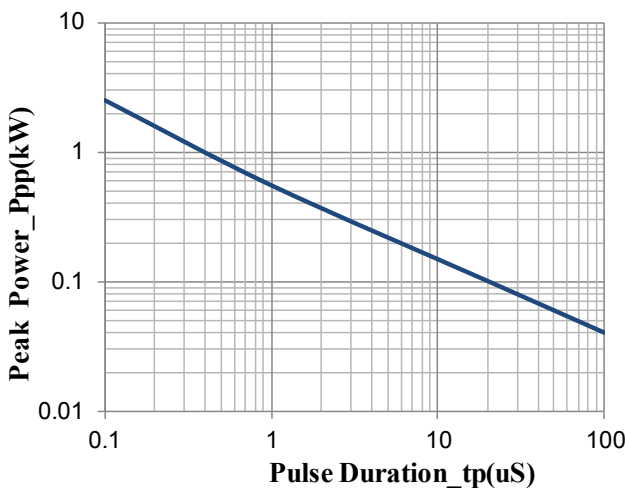

Peak Pulse Power vs. Pulse Time

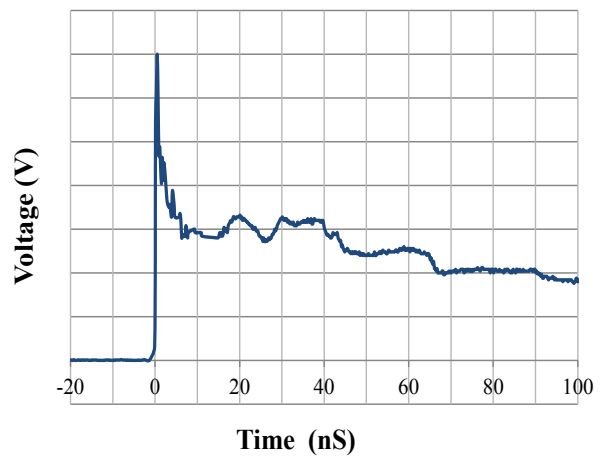

IEC61000-4-2 Pulse Waveform

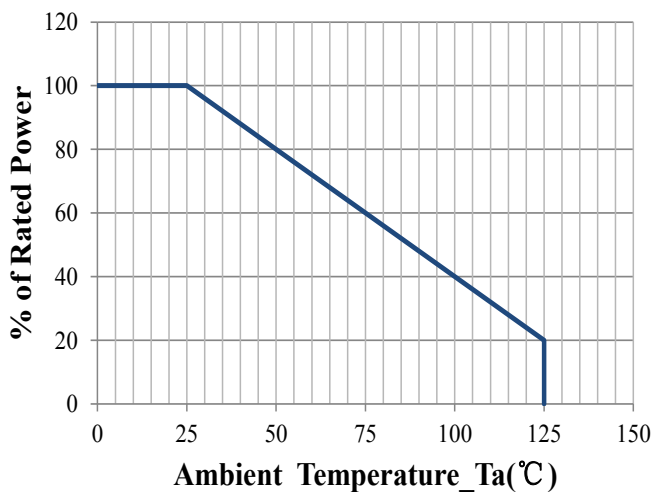

Power Derating Curve

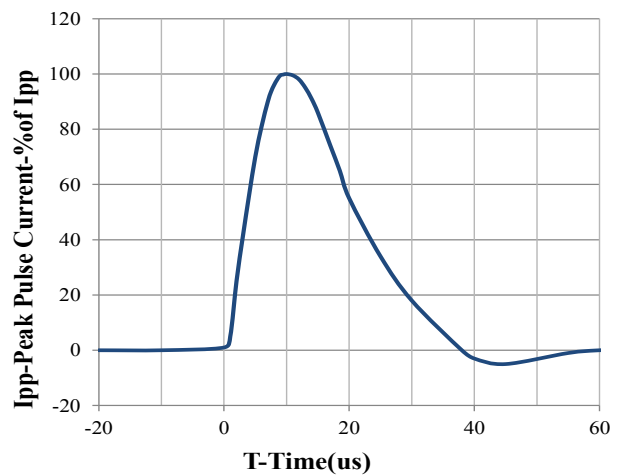

8 X 20us Pulse Waveform

## DFN1006-2 Package Outline Drawing

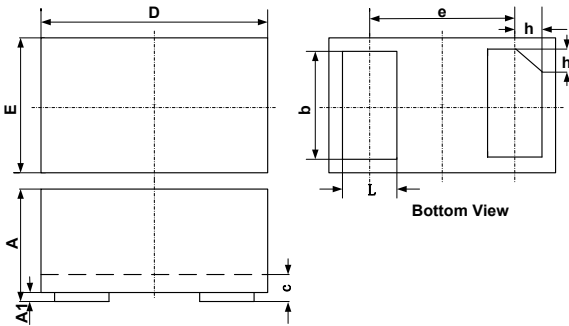

SYM	DIMENSIONS					
	MILLIMETERS			INCHES		
	MIN	NOM	MAX	MIN	NOM	MAX
A	0.45	0.50	0.55	0.018	0.020	0.022
A1	0.00	0.02	0.05	0.000	0.001	0.002
b	0.45	0.50	0.55	0.018	0.020	0.022
c	0.12	0.15	0.18	0.005	0.006	0.007
D	0.95	1.00	1.05	0.037	0.039	0.041
e	0.65 BSC			0.026 BSC		
E	0.55	0.60	0.65	0.022	0.024	0.026
L	0.20	0.25	0.30	0.008	0.010	0.012
h	0.07	0.12	0.17	0.003	0.005	0.007

## Suggested Land Pattern

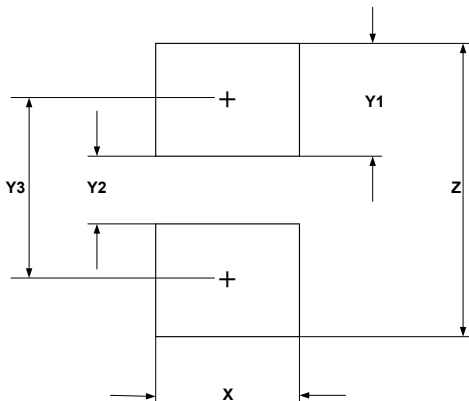

SYM	DIMENSIONS	
	MILLIMETERS	INCHES
X	0.60	0.024
Y1	0.50	0.020
Y2	0.30	0.012
Y3	0.80	0.032
Z	1.30	0.052