

ESD Protection Diode

Features

- 450Watts peak pulse power ($t_p = 8/20\mu s$)
- Unidirectional configurations
- Solid state silicon avalanche technology
- Low clamping voltage
- Low leakage current
- Protection one power line
- IEC 61000-4-2 $\pm 8kV$ contact $\pm 15kV$ air
- IEC 61000-4-4 (EFT) 20A (5/50ns)
- IEC 61000-4-5 (Lightning) 8A (8/20 μs)
- AEC-Q101 qualified (Automotive grade with suffix "Q")
- Exsemi technology



Circuit Diagram

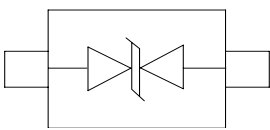

Applications

- * Cellular Handsets and Accessories
- * Personal Digital Assistants
- * Notebooks and Handhelds
- * Portable Instrumentation
- * Peripherals
- * Pagers Peripherals
- * Desktop and Servers

Marking Diagram

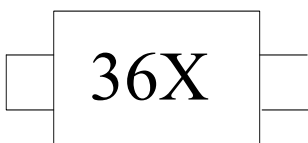

Transparent top view

36X: Device Marking Code

Absolute Maximum Ratings ($T_A=25^\circ\text{C}$ unless otherwise specified)

Parameter	Symbol	Value	Unit
Peak Pulse Power (8/20 μs)	Ppk	450	W
Peak Pulse Current (8/20 μs)	IPP	8	A
ESD per IEC 61000-4-2 (Air)	VESD	± 30	kV
ESD per IEC 61000-4-2 (Contact)		± 30	
Operating Temperature Range	TJ	-55 to +125	$^\circ\text{C}$
Storage Temperature Range	Tstg	-55 to +150	$^\circ\text{C}$

Electrical Characteristics ($T_A=25^\circ\text{C}$ unless otherwise specified)

Parameter	Symbol	Test Condition	Min	Typ	Max	Unit
Reverse Working Voltage	V_{RWM}				36	V
Breakdown Voltage	V_{BR}	$I_T = 1\text{mA}$	38.0	40.5	44	V
Reverse Leakage Current	I_R	$V_{RWM} = 36\text{V}$			0.5	μA
Clamping Voltage	V_C	$I_{PP} = 1\text{A}$ (8 x 20 μs pulse)		45	55	V
Clamping Voltage	V_C	$I_{PP} = 8\text{A}$ (8 x 20 μs pulse)		56	65	V
Junction Capacitance	C_J	$V_R = 0\text{V}$, $f = 1\text{MHz}$		20	40	pF

Portion Electronics Parameter

Symbol	Parameter
I_T	Test Current
I_{PP}	Maximum Reverse Peak Pulse Current
V_C	Clamping Voltage @ I_C

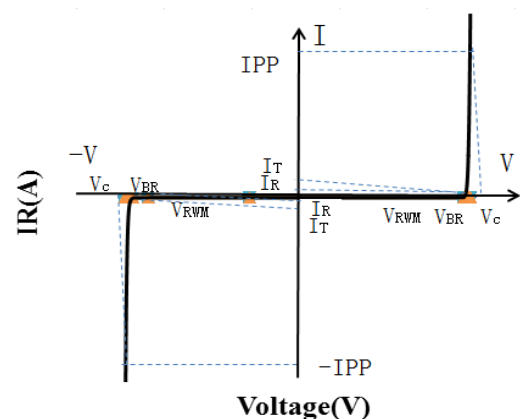

Typical Performance Characteristics ($T_A=25^{\circ}\text{C}$ unless otherwise Specified)

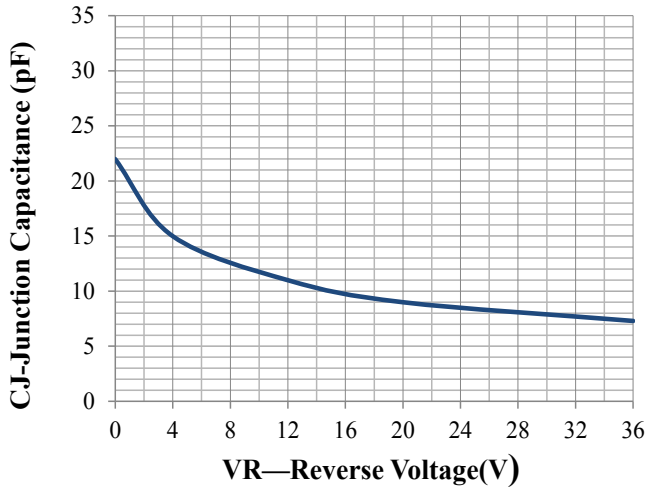

Junction Capacitance vs. Reverse Voltage

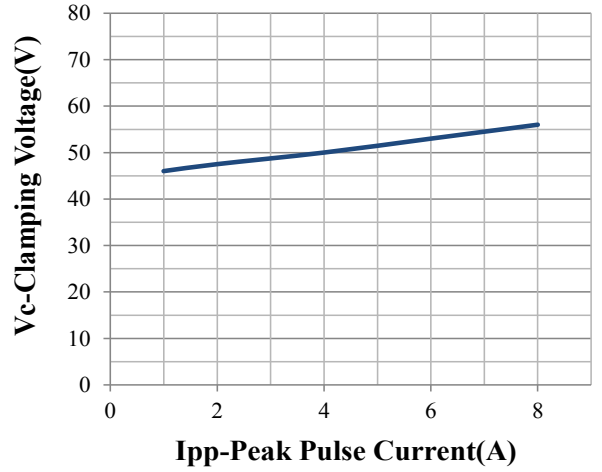

Clamping Voltage vs. Peak Pulse Current

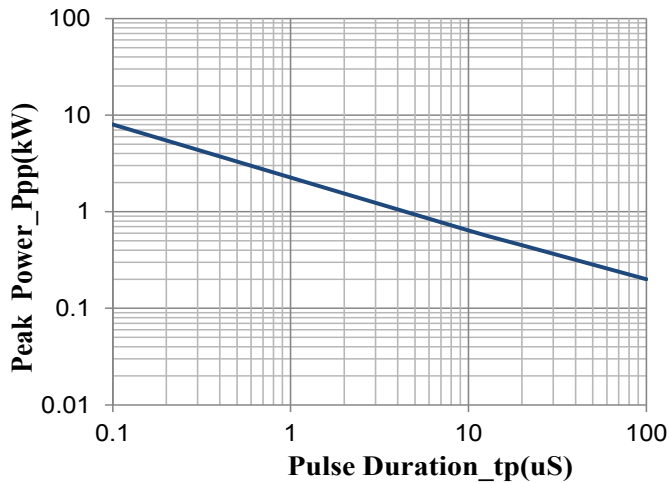

Peak Pulse Power vs. Pulse Time

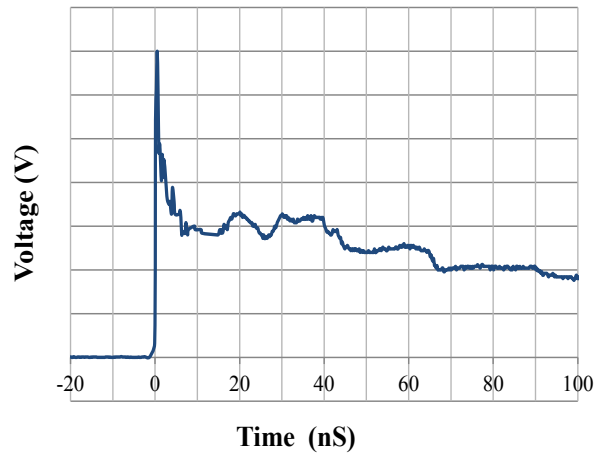

IEC61000-4-2 Pulse Waveform

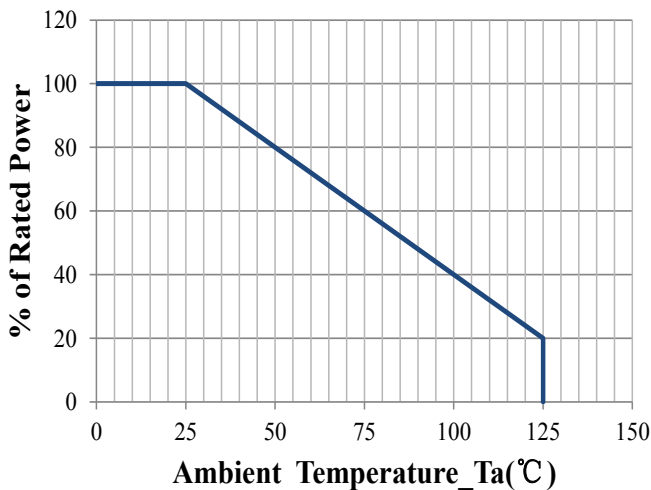

Power Derating Curve

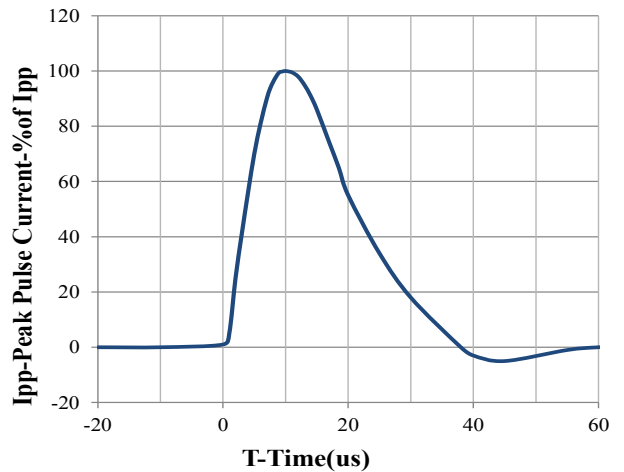

8 X 20us Pulse Waveform

SOD-523 Package Outline Drawing

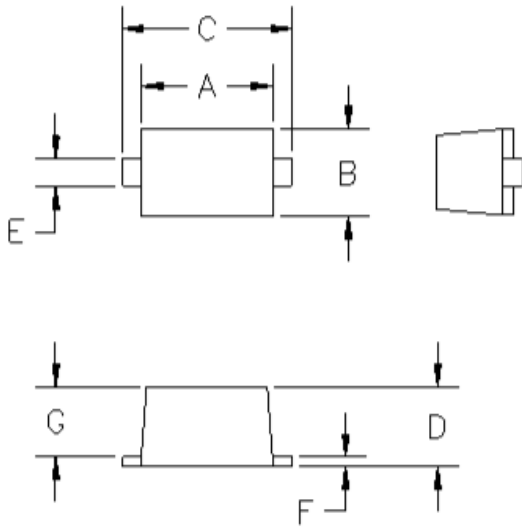

DIMENSIONS					
DIM ^N	INCHES		MM		NOTE
	. MIN	MAX	MIN	MAX	
A	.043	.051	1.10	1.30	—
B	.028	.035	0.70	0.90	—
C	.059	.067	1.50	1.70	—
D	.020	.028	0.50	0.70	—
E	.010	.014	0.25	0.35	—
F	.004	.008	0.10	0.20	—
G	.020	.028	0.50	0.70	—

Suggested Land Pattern

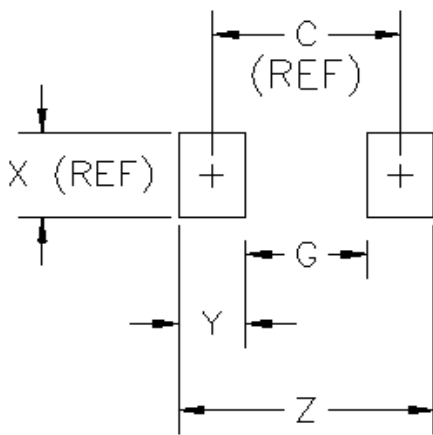

DIMENSIONS					
DIM ^N	INCHES		MM		NOTE
	MIN	MAX	MIN	MAX	
C	—	.067	—	1.70	REF
G	—	.043	—	1.10	—
X	—	.031	—	0.80	REF
Y	—	.024	—	0.60	—
Z	—	.091	--	2.30	—