

ESD Protection Diode

Features

- 3000Watts peak pulse power ($t_p = 8/20\mu s$)
- Tiny DFN1610 package
- Bidirectional configurations
- Solid-state silicon-avalanche technology
- Low clamping voltage
- Low leakage current
- Protection one data/power line to:
- IEC 61000-4-2 $\pm 30kV$ contact $\pm 30kV$ air
- IEC 61000-4-4 (EFT) 40A (5/50ns)
- IEC 61000-4-5 (Lightning) 140A (8/20 μs)
- AEC-Q101 qualified (Automotive grade with suffix "Q.")



Applications

- Cell Phone Handsets and Accessories
- Microprocessor based equipment
- Personal Digital Assistants (PDA's)
- Notebooks, Desktops, and Servers
- Portable Instrumentation

Mechanical Data

- DFN1610 package
- Molding compound flammability rating: UL 94V-0
- Packaging: Tape and Reel
- RoHS/WEEE Compliant

Schematic & PIN Configuration

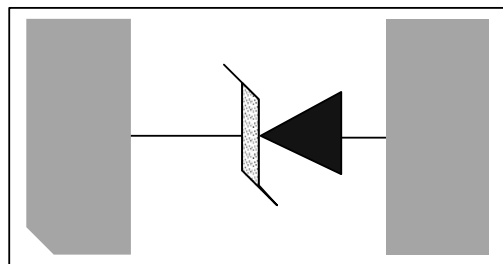

DFN1610

Absolute Maximum Rating

Rating	Symbol	Value	Units
Peak Pulse Power ($t_p = 8/20\mu s$)	P_{PP}	3000	Watts
Peak Pulse Current ($t_p = 8/20\mu s$)(note1)	I_{pp}	140	A
ESD per IEC 61000-4-2 (Air) ESD per IEC 61000-4-2 (Contact)	V_{ESD}	30 30	kV
Lead Soldering Temperature	T_L	260(10seconds)	$^{\circ}C$
Junction Temperature	T_J	-55 to + 125	$^{\circ}C$
Storage Temperature	T_{stg}	-55 to + 125	$^{\circ}C$

Electrical Characteristics

Parameter	Symbol	Conditions	Min	Typical	Max	Units
Reverse Stand-Off Voltage	V_{RWM}				7.0	V
Reverse Breakdown Voltage	V_{BR}	$I_T = 1mA$	7.2			V
Reverse Leakage Current	I_R	$V_{RWM} = 7.0V, T = 25^{\circ}C$		0.7	1.0	μA
Peak Pulse Current	I_{pp}	$t_p = 8/20\mu s$			140	A
Clamping Voltage	V_C	$I_{pp} = 140A, t_p = 8/20\mu s$		22		V
Junction Capacitance	C_j	$V_R = 0V, f = 1MHz$		1100		pF

Electrical Parameters (TA = 25°C unless otherwise noted)

Symbol	Parameter
I_{pp}	Maximum Reverse Peak Pulse Current
V_C	Clamping Voltage @ I_{pp}
V_{RWM}	Working Peak Reverse Voltage
I_R	Maximum Reverse Leakage Current @ V_{RWM}
V_{BR}	Breakdown Voltage @ I_T
I_T	Test Current

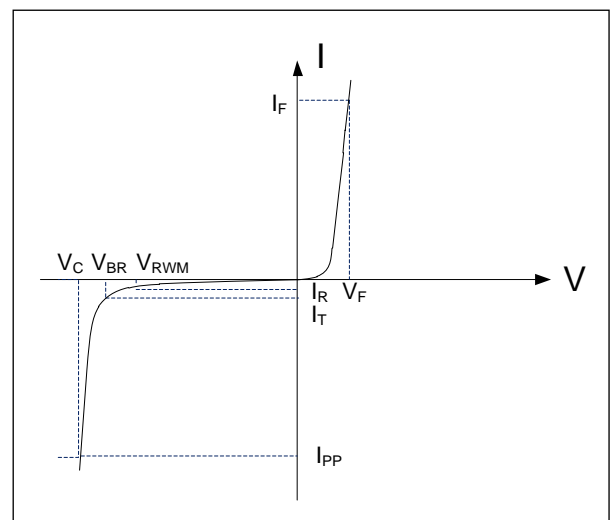

Note: 8/20 μs pulse waveform.

Typical Characteristics

Figure 1: Peak Pulse Power vs. Pulse Time

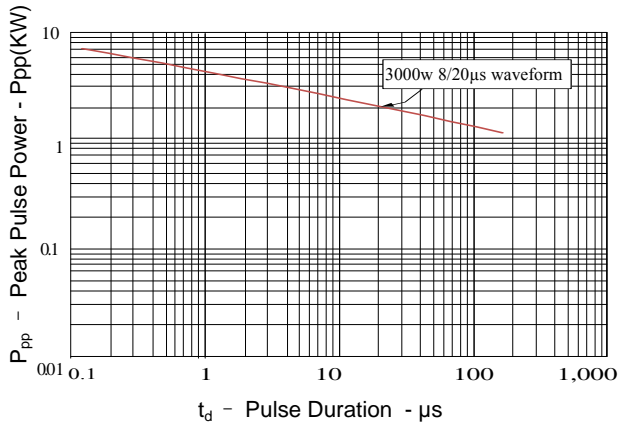

Figure 2: Power Derating Curve

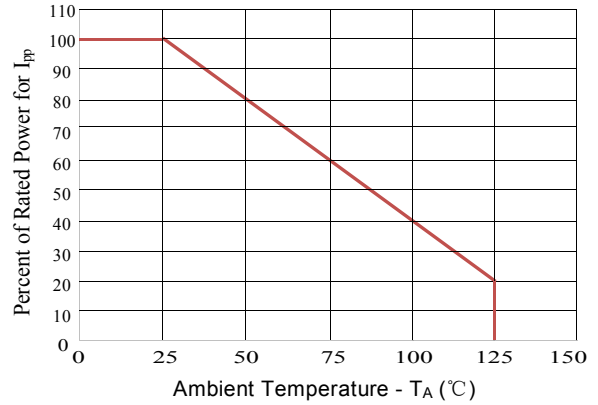

Figure3: Pulse Waveform

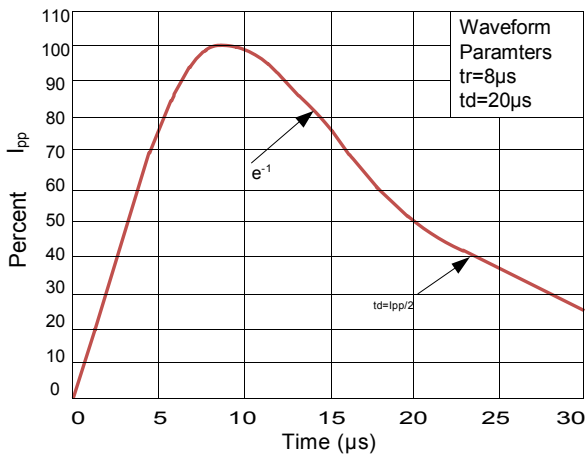
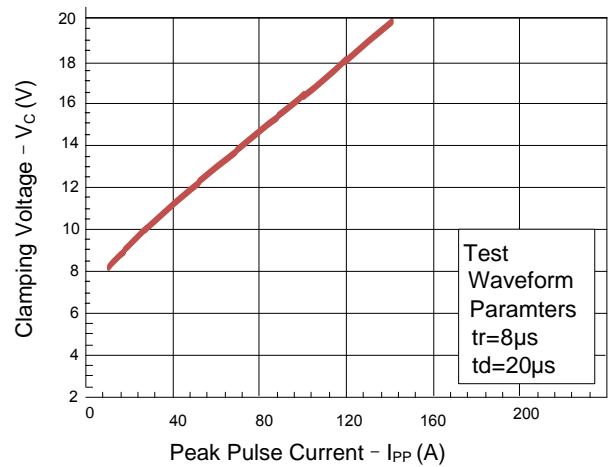
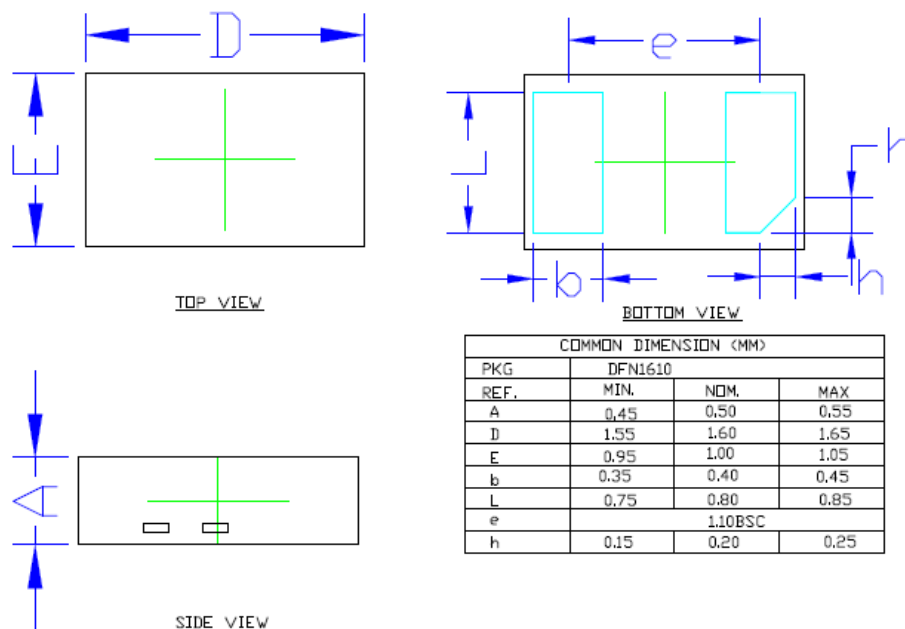

Figure 4: Clamping Voltage vs. Ipp



Outline Drawing – DFN1610



Marking

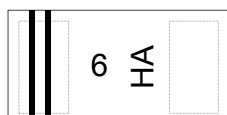

Ordering information

Order code	Package	Base qty	Delivery mode
EPD5A071V160	DFN1610	3k	Tape and reel