

## 1-Line Bi-directional TVS Diode

**Description**

The EP2421P1 is a 24V bi-directional TVS diode, utilizing leading monolithic silicon technology to provide fast response time and low ESD clamping voltage, making this device an ideal solution for protecting voltage sensitive data and power line. The EP2421P1 complies with the IEC 61000-4-2 (ESD) with  $\pm 30$  kV air and  $\pm 30$  kV contact discharge. It is assembled into an ultra-small lead-free DFN1006-2 package. The small size and high ESD surge protection make EP2421P1 an ideal choice to protect cell phone, digital cameras, audio players and many other portable applications.

**Mechanical Characteristics**

- ◆ Package: DFN1006-2 (1.0 x0.6 x0.5mm)
- ◆ Case Material: "Green" Molding Compound.
- ◆ Moisture Sensitivity: Level 3 per J-STD-020
- ◆ Terminal Connections: See Diagram Below
- ◆ Marking Information: See Below

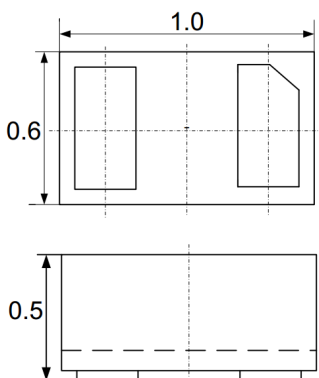
**Dimensions and Pin Configuration**

Package Dimensions

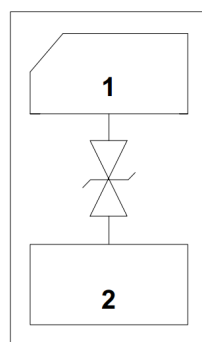

Circuit and Pin Schematic

**Features**

- ◆ Ultra small package: 1.0 x0.6 x0.5mm
- ◆ Protects one data or power line
- ◆ Ultra low leakage: nA level
- ◆ Operating voltage: 24V
- ◆ Low clamping voltage
- ◆ 2-pin leadless package
- ◆ Complies with following standards:
  - IEC 61000-4-2 (ESD) immunity test
    - Air discharge:  $\pm 30$  kV
    - Contact discharge:  $\pm 30$  kV
  - IEC61000-4-5 (Lightning) 6A (8/20 $\mu$ s)
- ◆ RoHS Compliant
- ◆ AEC-Q101 qualified (Automotive grade with suffix "Q").
- ◆ Exsemi technology

**Applications**

- ◆ Cellular Handsets and Accessories
- ◆ Personal Digital Assistants
- ◆ Notebooks and Handhelds
- ◆ Portable Instrumentation
- ◆ Digital Cameras
- ◆ Peripherals
- ◆ Audio Players

**Marking Information**

4B = Device Marking Code

**Ordering Information**

Part Number	Marking	Packaging	Reel Size
EP2421P1	4B	10000/Tape & Reel	7 inch

**Absolute Maximum Ratings (T<sub>A</sub>=25°C unless otherwise specified)**

Parameter	Symbol	Value	Unit
Peak Pulse Power (8/20μs)	P <sub>pk</sub>	300	W
Peak Pulse Current (8/20μs)	I <sub>pp</sub>	6	A
ESD per IEC 61000-4-2 (Air) ESD per IEC 61000-4-2 (Contact)	V <sub>ESD</sub>	±30 ±30	kV
Operating Temperature Range	T <sub>J</sub>	-55 to +125	°C
Storage Temperature Range	T <sub>stg</sub>	-55 to +150	°C

**Electrical Characteristics (T<sub>A</sub>=25°C unless otherwise specified)**

Parameter	Symbol	Min	Typ	Max	Unit	Test Condition
Reverse Working Voltage	V <sub>RWM</sub>			24	V	
Breakdown Voltage	V <sub>BR</sub>	26.7			V	I <sub>T</sub> = 1mA
Reverse Leakage Current	I <sub>R</sub>			0.2	μA	V <sub>RWM</sub> = 24V
Clamping Voltage	V <sub>C</sub>		32	34	V	I <sub>PP</sub> = 1A (8 x 20μs pulse)
Clamping Voltage	V <sub>C</sub>		50	52	V	I <sub>PP</sub> = 6A (8 x 20μs pulse)
Junction Capacitance	C <sub>J</sub>		14	20	pF	V <sub>R</sub> = 0V, f = 1MHz

**Typical Performance Characteristics (TA=25°C unless otherwise Specified)**

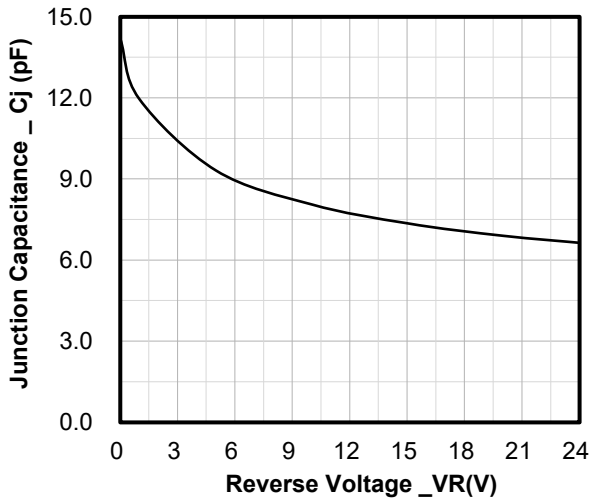

**Junction Capacitance vs. Reverse Voltage**

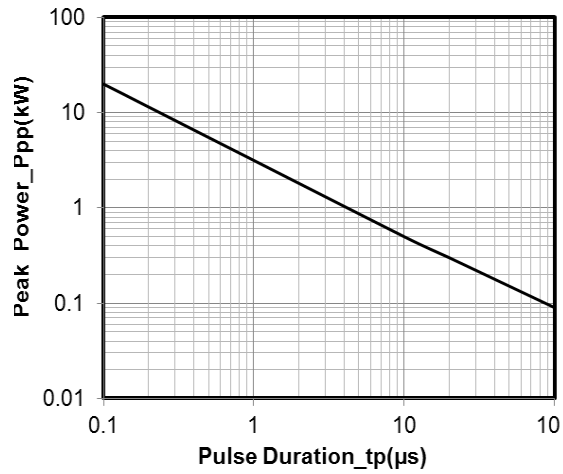

**Peak Pulse Power vs. Pulse Time**

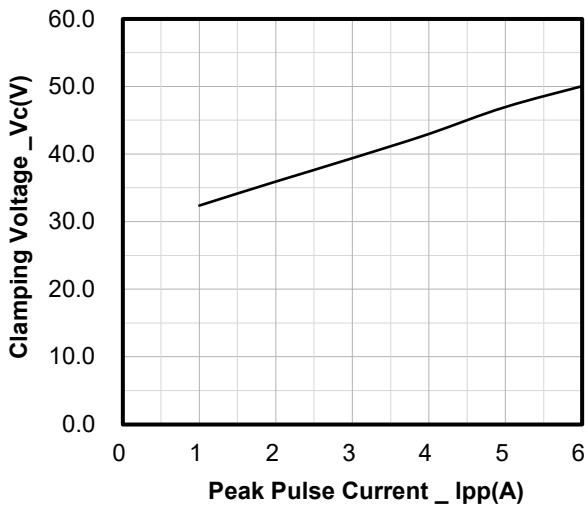

**Clamping Voltage vs. Peak Pulse Current**

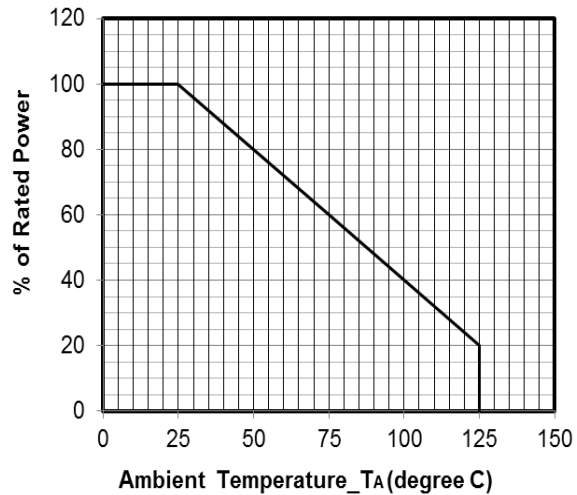

**Power Derating Curve**

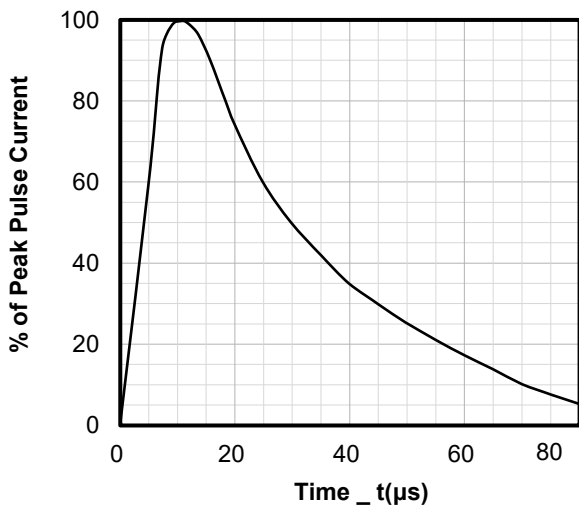

**8 X 20μs Pulse Waveform**

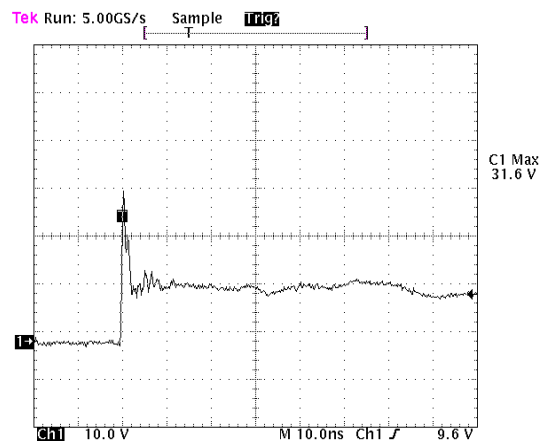

**Note: Data is taken with a 10x attenuator**

**ESD Clamping Voltage  
8 kV Contact per IEC61000-4-2**

**DFN1006-2 Package Outline Drawing**

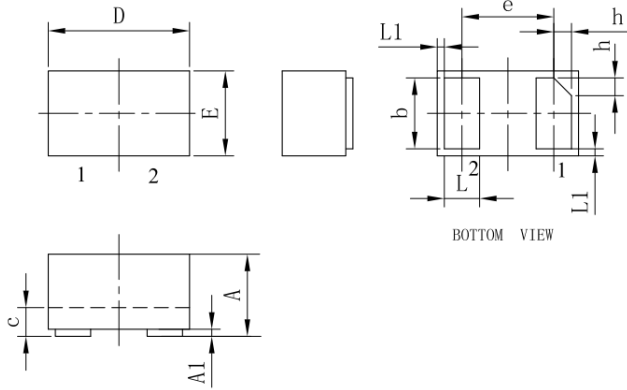

SYM	DIMENSIONS					
	MILLIMETERS			INCHES		
	MIN	NOM	MAX	MIN	NOM	MAX
A	0.450	0.500	0.550	0.018	0.020	0.022
A1	0.000	0.020	0.050	0.000	0.001	0.002
b	0.450	0.50	0.550	0.018	0.020	0.022
c	0.120	0.150	0.180	0.005	0.006	0.007
D	0.950	1.000	1.050	0.037	0.039	0.041
e	0.65 BSC			0.026 BSC		
E	0.55	0.60	0.65	0.022	0.024	0.026
L	0.20	0.25	0.30	0.008	0.010	0.012
L1	0.05REF			0.002REF		
h	0.07	0.12	0.17	0.003	0.005	0.007

**Suggested Land Pattern**

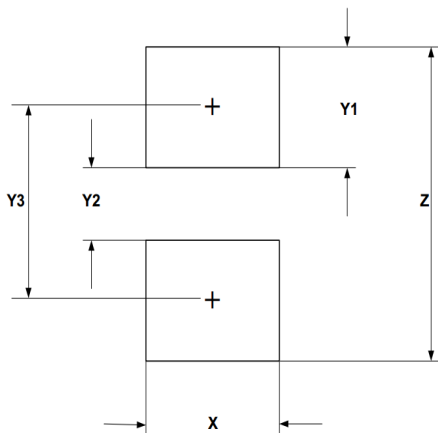

SYM	DIMENSIONS	
	MILLIMETERS	INCHES
X	0.60	0.024
Y1	0.50	0.020
Y2	0.30	0.012
Y3	0.80	0.032
Z	1.30	0.052